

# **FMS**

## **1/18 CHEVROLET K10 V2**

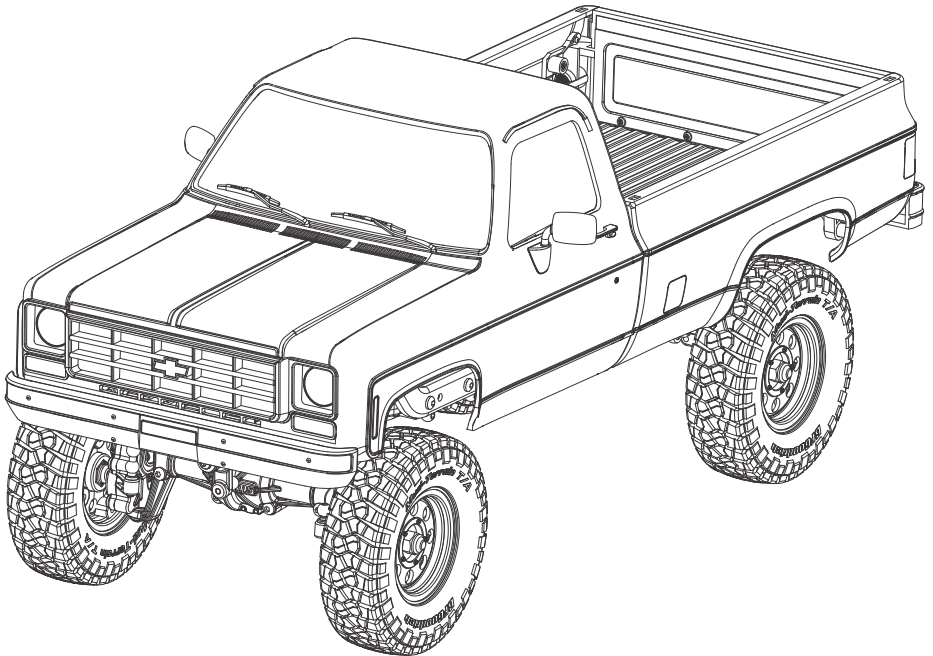

# **FCX18**

MAN-G0250V2

*Instruction Manual*  
操作手册

**Introduction 指引**

Thank you for purchasing our products.

This manual is written to assist you in properly operating, maintaining and repairing the vehicle. As many of the components used are unique to this product, please retain this manual as a future reference. Composed of precision-made components, this product is not a toy, thus it is not suited for children under 14 years of age. Minors should be accompanied by an adult when operating. Failure to operate or maintain this product in a safe manner can result in bodily harm. It is the owner responsibility to operate this product in a safe manner. FMS and its distributors are not responsible in any way for any and all bodily harm and/ or property damage that may result from the use of this product.

感谢您购买我们的产品。

本手册旨在帮助您正确操作、维护和修理车辆。由于本品所涉部件多数为特有部件，请保留本手册作为未来参考之用。

本产品由精密部件组成，并非玩具，因此不适合 14 岁以下的少年或儿童使用。未成年人操作时应有成人陪同。未能以安全的方式操作或维护本产品可能会导致人身伤害。以安全的方式操作本产品是所有者的责任。FMS 及其分销商对使用本产品可能导致的任何和所有人身伤害和/或财产损失概不负责。

**Safety, precautions and warnings 安全、预防措施及警告**

- Replace damaged components with original factory-parts. Pay special attention to the polarity of all vehicle wiring.
- Use common sense when selecting the environment to operate your vehicle. Do not operate near power cables, cellular/radio towers, deep water or unstable terrain. The operator is solely responsible for their actions.
- The product is composed of precision electrical components. It is critical to keep the product away from moisture and other contaminants.
- Always check the radio range of the vehicle prior to operation in order to prevent radio loss or interference.
- Operate this product within your ability. If the vehicle is dangerous to retrieve, it never worth the risk.
- Always turn on the transmitter before connecting the battery on the model. When turning off the model, always disconnect the battery first, and then turn off the transmitter. If this order is reversed, the model may become uncontrollable and cause serious damage.
- Never allow transmitter batteries to run low as it may cause loss of vehicle control.
- Plastics on the vehicle are susceptible to damage or deformation due to extreme heat and cold climate. Do not store the model near any source of heat such as oven or heater. Store the model indoors, in a climate-controlled, room temperature environment.
- 请使用原厂部件更换损坏的部件。特别注意所有车辆接线的正负极。
- 务必选择合适的环境操作遥控模型，所选环境需远离电缆、无线电塔、深水及不稳定地形。本品操作者对其行为全权负责。
- 本品由精密电子部件构成。请勿将本品暴露于潮湿的环境或者其他污染物中。
- 确保每次操作前检查车辆的无线接收范围，以防止无线信号丢失或受干扰。
- 在您的能力范围内操作此产品。在任何时候，如果车辆操作有危险，则绝对不值得冒险。
- 通电方式：务必先开遥控器再将车子通电。断电方式：务必先将车子断电再关遥控器。以上顺序如逆转，则可能引起遥控模型失控，导致人身伤害或财产损失。
- 遥控器电池低电时，请勿操作模型车，以免出现失控。
- 模型产品上的塑胶件容易因极冷或极热气候出现变形或损坏的状况。所以请将模型产品存放在气候受控的室温环境中，切勿靠近任何热源，如烤箱或加热器等。

## Safety Precautions

## 安全保障措施

This product is not a toy! (14+) Recommended for ages 14 and up. Adult supervision required for ages under 14 years old. Contains small parts, keep out of reach of children 3 years of age and younger.

使用前请仔细阅读本手册。我们不对任何故意损坏或不当使用负责。这个产品不是玩具！建议14岁及以上者使用。14岁以下的用户，需要在成年人监督下使用。本产品部分包含小零件，请务必保证3岁及以下儿童不能接触本产品。

### CE Warning

The antenna(s) used for this transmitter must be installed to provide a separation distance of at least 20 cm from all persons and must not be co-located or operating in conjunction with any other transmitter. End-users and installers must be provided with antenna installation instructions and transmitter operating conditions for satisfying RF exposure compliance.

### FCC Statement

This equipment has been tested and found to comply with the limits for a Class B digital device pursuant to part 15 of the FCC rules. These limits are designed to provide reasonable protection against harmful interference in a residential installation. This equipment generates, uses and can radiate radio frequency energy and, if not installed and used in accordance with the instructions, may cause harmful interference to radio communications. However, there is no guarantee that interference will not occur in a particular installation. If this equipment does cause harmful interference to radio or television reception, which can be determined by turning the equipment off and on, the user is encouraged to try to correct the interference by one or more of the following measures:

- Reorient or relocate the receiving antenna.
- Increase the separation between the equipment and receiver.
- Connect the equipment into an outlet on a circuit different from that to which the receiver is connected.
- Consult the dealer or an experienced radio/TV technician for help.

To assure continued compliance, any changes or modifications not expressly approved by the party responsible for compliance could void the user's authority to operate this equipment.

This equipment complies with Part 15 of the FCC Rules. Operation is subject to the following two conditions:

- (1) This device may not cause harmful interference.
- (2) This device must accept any interference received, including interference that may cause undesired operation.

Caution!

The manufacturer is not responsible for any radio or TV interference caused by unauthorized modifications to this equipment. Such modifications could void the user authority to operate the equipment.

1. The antenna(s) used for this transmitter must be installed to provide a separation distance of at least 20 cm from all persons and must not be co-located or operating in conjunction with any other transmitter. End-users and installers must be provided with antenna installation instructions and transmitter operating conditions for satisfying RF exposure compliance.

2. Move all your channels to the desired position.

3. Select [All channels] and then [Yes] in the confirmation box.

### Environmentally friendly disposal

Old electrical appliances must not be disposed of together with the residual waste, but have to be disposed of separately. The disposal at the communal collecting point via private persons is for free. The owner of old appliances is responsible to bring the appliances to these collecting points or to similar collection points. With this little personal effort, you contribute to recycle valuable raw materials and the treatment of toxic substances.

CAUTION

RISK OF EXPLOSION IF BATTERY IS REPLACED BY AN INCORRECT TYPE.

DISPOSE OF USED BATTERIES ACCORDING TO THE INSTRUCTIONS



## IC STATEMENT

This device contains licence-exempt transmitter(s)/receiver(s) that comply with Innovation, Science and Economic Development Canada's licence-exempt RSS(s). Operation is subject to the following two conditions:

- (1) This device may not cause interference.
- (2) This device must accept any interference, including interference that may cause undesired operation of the device.

L'émetteur/récepteur exempt de licence contenu dans le présent appareil est conforme aux CNR d'Innovation, Sciences et Développement économique Canada applicables aux appareils radio exempts de licence.

L'exploitation est autorisée aux deux conditions suivantes :

1. L'appareil ne doit pas produire de brouillage;
2. L'appareil doit accepter tout brouillage radioélectrique subi, même si le brouillage est susceptible d'en compromettre le fonctionnement.

IC: 25584-MG4BS00

IC: 25584-R4A31

## Radio System 无线电系统

### Safety symbols 安全符号

Pay close attention to the following symbols and their meanings. Failure to follow these warnings could cause damage, injury or death.

仔细阅读以下符号及其相关说明，如不按照以下指引进行操作，可能会导致设备损坏或人员伤亡。



**Not following these instructions may lead to serious injuries or death.**

如果使用者不按照说明方法操作，有可能导致操作者或他人受到轻微伤害。



**Not following these instructions may lead to major injuries.**

如果使用者不按照说明方法操作，有可能导致操作者或他人受到轻微伤害。



**Not following these instructions may lead to minor injuries.**

如果不按照说明方法操作，可能导致操作者或他人严重受伤，甚至遭受生命危险。

### Safety guide 安全信息

#### Prohibited 禁止

- Do not use the product at night or in bad weather like rain or thunderstorm. It can cause erratic operation or loss of control.
- Do not use the product when visibility is limited.
- Do not use the product on rain or snow days. Any exposure to moisture (water or snow) may cause erratic operation or loss of control.
- Interference may cause loss of control. To ensure the safety of you and others, do not operate in the following places:
  - 1、Near any site where other radio control activity may occur
  - 2、Near power lines or communication broadcasting antennas
  - 3、Near people or roads
  - 4、On any body of water when passenger boats are present
- Do not use this product when you are tired, uncomfortable, or under the influence of alcohol or drugs. Doing so may cause serious injury to yourself or others.
- The 2.4GHz radio band is limited to line of sight. Always keep your model in sight as a large object can block the RF signal and lead to loss of control.
- Do not touch any part of the model that may generate heat during operation, or immediately after use. The engine, motor or speed control, may be very hot and can cause serious burns.

# Radio System 无线电系统

- 请不要在夜晚或雷雨天气使用本产品，恶劣的天气环境有可能导致遥控设备失灵。
- 请不要在能见度有限的情况下使用本产品。
- 请不要在雨雪或有水的地方使用本产品。如果有液体进入到系统内部，可能会导致运行不稳定或失灵。
- 信号干扰可能导致设备失控。为保证您和他人的安全，请不要在以下地点使用本产品：
  - 1、通信基站附近或其他无线电活跃的地方
  - 2、人多的地方或道路附近
  - 3、水域附近
  - 4、高压电线或通信广播天线附近
- 当您感到疲倦、不舒服，或在摄入酒精或服食导致麻醉或兴奋的药物后，不要操作本产品。否则可能对自己或他人造成严重的伤害。
- 2.4GHz无线电波段完全不同于之前所使用的低频无线电波段。使用时请确保模型产品在您的视线范围内，大的障碍物将会阻断无线电频率信号从而导致遥控失灵模型失控。
- 请勿在操作过程中或使用后立即触摸模型可能产生热量的任何部分。发动机、电机或速度控制器可能非常热，并可能导致严重烧伤。

## Mandatory 强制

- Misuse of this product may lead to serious injury or death. To ensure the safety of you and your equipment, read this manual and follow the instructions.
- Make sure the product is properly installed in your model. Failure to do so may result in serious injury.
- Make sure to disconnect the receiver battery before turning off the transmitter. Failure to do so may lead to unintended operation and cause an accident.
- Ensure that all servos operate in the correct direction. If not, adjust the direction first.
- Make sure the model stays within the systems maximum range to prevent loss of control.
- 遥控设备使用不恰当可能导致操作者或他人严重受伤，甚至死亡。为保证您和设备的安全，请仔细阅读使用说明书并按照要求进行操作。
- 使用前必须确保本产品与模型安装正确，否则可能导致模型发生严重损坏。
- 关闭时，请务必先关闭接收机电源，然后关闭发射机。如果关闭发射机电源时接收机仍然在工作，将有可能导致遥控设备失控或者引擎继续工作而引发事故。
- 操控时，请先确认模型所有舵机的动作方向与操控方向一致。如果不一致，请调整好正确的方向。
- 当遥控距离较远时，有发生失控的可能，请适当缩短遥控距离。

## Background 产品背景

The development of Chevrolet K10 can be traced back to the early 1960s. During that period, the demand for pickup trucks in the American automotive market began to grow, especially for industrial, agricultural, and outdoor activities, where a robust and durable pickup truck was needed to fulfill various purposes. In this context, Chevrolet, as a brand under General Motors, introduced the first-generation C/K series pickup trucks aimed at meeting these demands, and the Chevrolet K10 was one of them.

The main focus of the Chevrolet K10's development was on performance and durability to cater to a wide range of industrial, agricultural, and off-road needs. To achieve these goals, the Chevrolet engineering team conducted extensive research and development work, with an emphasis on strengthening the body structure, enhancing the suspension system, and optimizing the four-wheel-drive system to ensure outstanding performance in harsh conditions.

Meanwhile, the exterior design of the Chevrolet K10 also embodies the characteristics of the American automotive culture of that era. It adopted the typical American large-size design style, featuring a square and rugged body profile with a spacious cabin area, presenting a commanding and luxurious appearance. The interior layout was comfortable and practical, meeting the expectations of the time for a pickup truck that could serve both family and commercial purposes.

During the 1960s, the pickup truck market in the United States experienced continuous growth, and Chevrolet K10 quickly gained widespread market recognition due to its excellent performance, reliability, and durability. Its versatility made it popular not only in rural and countryside areas but also attracted attention from urban residents, becoming a popular choice for a household pickup truck.

Over time, Chevrolet K10 underwent continuous improvements and upgrades to adapt to the ever-changing market demands and technological advancements. It evolved from a simple and practical workhorse to a stylish and multifunctional pickup truck, catering to various needs from utilitarian to luxurious.

Chevrolet K10的研发背景可以追溯到上世纪60年代初。在那个时期，美国汽车市场对皮卡车型的需求开始增长，特别是在工农业和户外活动中，需要一款强大耐用的皮卡来满足多种用途。在这个背景下，雪佛兰（Chevrolet）作为通用汽车旗下品牌，推出了旨在满足这些需求的第一代C/K系列皮卡车，Chevrolet K10就是其中之一。

Chevrolet K10的研发目标主要集中在可靠性和耐用度上，以适应各种工农业用途和越野需求。为了实现这些目标，Chevrolet工程师团队做了大量的研发工作，强化车身结构、强化悬挂系统和优化四驱系统，确保其在各种恶劣条件下都表现出色。

与此同时，Chevrolet K10的外观设计也体现了当时美国汽车文化的特点。它采用了典型的美式大尺寸，拥有方正硬朗的车身线条和大面积的车厢空间，在外观上显得强势而豪华。内部空间布局舒适实用，符合当时人们对皮卡的期望，可同时适应家庭和商业用途的需求。

1960年代，美国的皮卡市场持续增长，而Chevrolet K10凭借其出色的性能、可靠性和耐用性，迅速赢得了广泛的市场认可。其多功能性使得它不仅在农村和乡村地区受欢迎，还吸引了城市居民的关注，成为家用皮卡的热门选择。

随着时间的推移，Chevrolet K10不断进行改进和升级，以适应不断变化的市场需求和技术发展。从简单实用到豪华升级，从硬朗的工作型皮卡到时尚的休闲座驾，Chevrolet K10演变成了一款集实用性和时尚性于一身的多功能皮卡。

Licensed by General Motors LLC, this remote-control simulation model FMS FCX18 Chevrolet K10 maximizes its static and dynamic value in one compact package. The FCX18 K10, much like its original prototype, features a spacious cabin and a trapezoidal girder chassis, showcasing the iconic American style of the original vehicle. The body features an advanced dual-color combination, with exquisite electroplated process used on various components such as the front grille (including headlight housings), front and rear bumpers, and rearview mirrors. The tailgate can be opened, facilitating the addition of various 1:18 scale simulated components like motorbikes, kayaks, and various camping equipment. The spacious compartment hidden beneath the hood provides clear visibility of electronic configurations, making routine maintenance and upgrades convenient. Utilizing lighting control modules that replicate the real car's lighting effects, the model features synchronized lighting control for headlights, turn signals, and taillights. Furthermore, it comes equipped with soft, large-sized all-terrain tires and highly realistic specialized chrome-plated wheel hubs, allowing for leisurely strolls or high-speed dashes.

To faithfully recreate the off-road capabilities and handling experience of the original vehicle, FMS has made remarkable progress by deriving the FCX18 chassis from the FCX24 series chassis. The FCX18 chassis adopts a metal beam construction, as well as metal bars (6pcs), metal steering rod and linkage that are capable of maintaining performance in extreme environments. The mid-mounted power assembly has a low center of gravity and integrates a 2-speed transmission, transfer case and a 180 brushed motor. The power is transmitted to the front and rear axles through the universal joint drive shaft. The axles are equipped with wheel side reducers, commonly known as "portal axles", which can increase the ground clearance of the differential tooth pack and improve passability.

The FCX18 is equipped with a straight axle by default, but the planetary gear differential can also be replaced with high-viscosity silicone oil to simulate the driving effect of an LSD (limited-slip differential). After installing the differential, the ultimate climbing ability will be reduced, but a smaller turning radius and a more stable high-speed driving quality can be obtained.

The two-speed gearbox uses CH3 of the remote control and is operated by a 9G steering gear. The low gear reduction ratio is 99, which is larger than that of similar products currently on the market. The torque output is strong, and easy for extreme climbing. The high gear reduction ratio is 24.75, and the speed is higher than that of all similar products currently on the market. You can experience the fun of high-speed, small jumps, and even wheelies.

A variety of upgraded and modified parts such as metal differential, metal universal joint drive shaft, brass wheel counterweights and trailers (three styles) etc. will be launched to match the FCX18 chassis for further improving the performance of the vehicle.

The FMS Chevrolet K10 can truly be described as an exquisite static model that embodies the capabilities of trailing, racing, and crawling.

由通用汽车公司授权，FMS模型出品的这款遥控仿真模型车FCX18 Chevrolet K10在极为有限的空间里将其静态和动态的价值发挥到极致。FCX 18 K10和真车一样使用宽敞的驾驶室和梯形大梁车架，展现原车典型的美式风格。车身使用高级的双色搭配，前格栅（及大灯灯座）、前后保险杠、后视镜等多处都使用精致的电度零件；尾门可开合，方便搭载各类1:18的仿真零件如摩托车、皮划艇以及各种露营装备；引擎盖下的空间足够大，电子配置一目了然，方便日常维修及升级；采用与真车灯效一致的灯控插件，大灯、转向灯、尾灯均有联动灯控功能；匹配柔软的大尺寸全地形轮胎和高还原度的专用电镀轮毂，可在任意地形悠闲行走或疾速飞驰。

K10采用FCX18攀爬底盘，以还原原车的越野性能和操控体验。FCX18底盘采用金属大梁、金属拉杆（6pcs）、金属转向拉杆和金属转向连杆，能在极端环境下保持高稳定性，中置动力总成重心低，将2档变速机构、分动箱和180大扭力有刷电机整合为一体。动力通过万向节传动轴传输到前后两个车桥，车桥装有轮边减速器，俗称“门桥”，可以加大差速器牙包的离地间隙，提高通过性，在崎岖的路面上表现尤为出色。

FCX18默认搭载直轴，但也可以更换行星齿差速器，搭配高粘度硅油，模拟LSD限滑差速器的行驶效果。安装差速器后极限攀爬能力将会降低，但可以获得更小的转向半径，更稳定的高速行驶品质。

两档变速箱使用遥控器第三通道，通过一颗9G舵机操作，低速档减速比99，大于目前市面上的同类产品，低扭输出强劲，极限攀爬游刃有余。高速档减速比24.75，车速大于目前市面上所有同类产品，可以体验高速冲破，小跳，甚至抬头的乐趣。

此外，配合FCX18底盘，包括金属差速器、金属万向节传动轴、黄铜轮毂配重、多款拖车等大量升级改装零件会同步推出，使玩家可以进一步提升车辆性能，打造独属于自己的皮卡。

FMS雪佛兰K10可以说得上是可以行走、飞驰和攀爬的静态模型。

## Features 特点

●GENERAL MOTORS LLC LICENSED PRODUCT ●HIGHLY DETAILED ROLES& COCKPITS ●METAL GEARS ●READY TO RUN MODEL ●POWER CONFIGURATION INCLUDES 3-IN-1 RECEIVER/ESC/LIGHT CONTROL, 180 BRUSHED MOTOR AND 7.4V 900MAH BATTERY ●NON-LOAD-BEARING CLIMBING VEHICLE CHASSIS ●METAL BARS (6PCS) AND METAL STEERING ROD & LINKAGE ●HEADLIGHTS, TURN SIGNALS, AND TAILLIGHTS, MULTIPLE LIGHT EFFECTS AND CONTROL MODES ●TWO-SPEED TRANSMISSION ●PORTAL AXLES (METAL GEAR) ●BALL BEARINGS FULL SET (24PCS) ●METAL-GEAR STEERING SERVO ●FOUR-LINK SUSPENSION ●COIL SPRINGS + METAL OIL DAMPER ●4WD ●RIGID METAL GIRDER ●OPENABLE HOOD ●PAINTED BODY ●THREE COLOR OPTIONS ●OPTIONAL MODIFICATION PARTS, LIKE METAL DIFFERENTIAL, METAL UNIVERSAL JOINT DRIVE SHAFT, BRASS WHEEL COUNTERWEIGHTS AND TRAILERS (THREE STYLES)

●通用汽车公司授权产品 ●像真人偶&驾驶舱 ●金属齿轮 ●RTR组装完成品●电子配置包括180有刷电机，电调、接收机、灯控三合一模块，7.4V 900mAh锂电●非承载式攀爬车底盘●金属拉杆（6根）和金属转向拉杆和转向连杆●大灯、转向灯、尾灯多种灯效和遥控模式●微型两档机械变速●门式车桥（金属齿轮）●全车滚珠轴承（24颗）●金属齿转向舵机●四连杆悬挂●螺旋弹簧+金属油压避震●四轮驱动●金属大梁●引擎盖可打开●喷涂完成车壳●三款涂装可选 ●丰富的可选配升级改装零件，如金属差速器、金属万向节传动轴、黄铜轮毂配重、拖车(3种形态)等

## Specification 产品参数

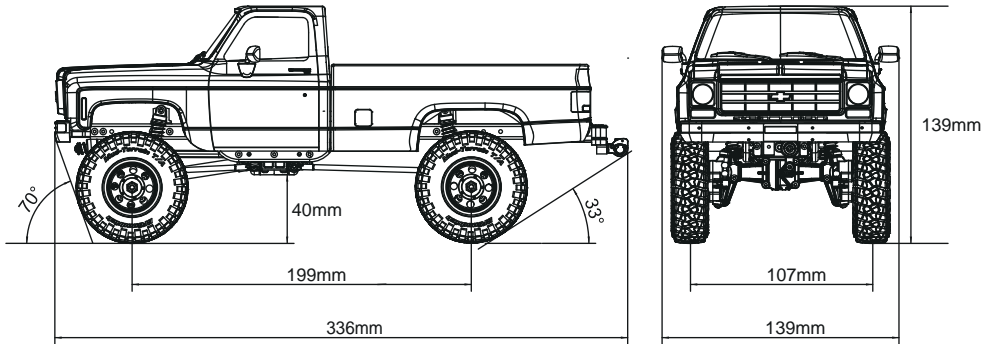

- Length:336mm
- Width:139mm
- Height:139mm
- Wheelbase:199mm
- Tire F/R :Φ 66\*22mm
- Minimum Ground Clearance: 40mm
- Approach Angle: 70°
- Departure Angle: 33°

- Motor: 180 Brushed motor
- Battery : 2S Lipo 7.4V 900mAh x1
- Remote control distance: 30m
- Approx. operating duration time: 45mins
- Remote control:MG41-BS transmitter,  
R4A1 receiver with ESC  
group control board

- 车长:336mm
- 车宽: 139mm
- 车高: 139mm
- 轴距: 199mm
- 轮胎: Φ 66\*22mm
- 离地间隙: 40mm
- 接近角: 70°
- 离去角: 33°

- 电机: 180有刷电机
- 电池: 2S Lipo 7.4V 900mAh
- 遥控距离: 30m
- 续航: 45mins
- 遥控: MG41-BS发射机,  
R4A1接收机/电调 (二合一)

## Transmitter instruction 发射机介绍

The MG41-BS is a simplified 4-channel transmitter that adopts the 2.4GHz 2A-BS Automatic Frequency Hopping Digital System. The transmitter is lightweight and compact in design, comfortable and ergonomic. It has a beginner mode and is easy for beginner players to use.

MG41-BS 是一款采用 2.4GHz 2A-BS 协议自动跳频数字系统的简版 4 通道双向发射机，外观设计轻便小巧，手感舒适，符合人体工程学，可通过发射机设置电调参数。该款发射机还具备初学者模式方便入门玩家使用。

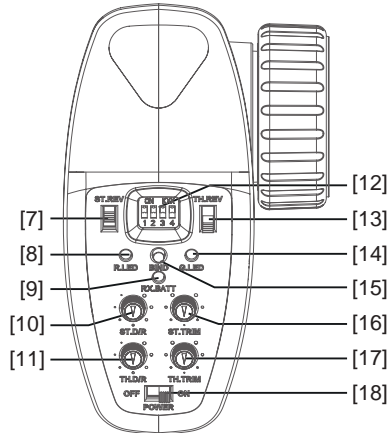
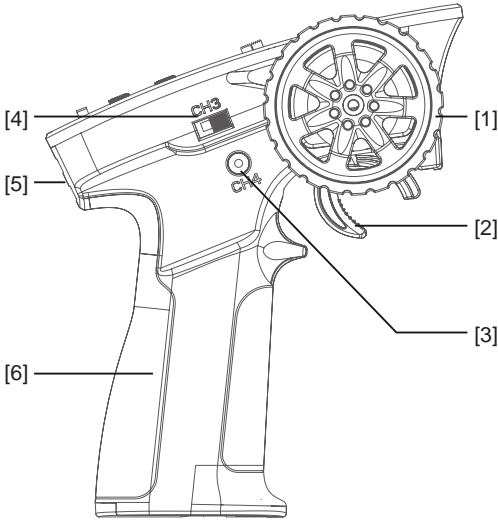

- [1] Steering Wheel, 35 degrees on each side (CH1)  
方向手轮，左右各 35 度 (CH1)
- [2] Throttle Trigger, 25 degrees forward and 12.5 degrees backward (CH2)  
油门扳机，前 25 度后 12.5 度 (CH2)
- [3] Push button switch (CH4) [Push button function is flip type]  
按键开关 (CH4) [ 按键功能为翻转式 ]
- [4] Three-position toggle switch (CH3)  
三档拨动开关 (CH3)
- [5] Lanyard hole  
挂绳孔
- [6] Handle, 4\*AAA battery compartment  
手柄，4\*AAA 电池仓
- [7] ST.REV (Steering wheel reverse)  
方向通道反向开关 (ST.REV)
- [8] R.LED(Power indicator)  
电源指示灯红色 LED (R.LED)
- [9] RX.BATT, ESC Battery Power Indicator  
电调电池电量显示指示灯 (RX.BATT)
- [10] ST.D/R, to adjust the D/R for steering channel.  
方向通道舵量调节旋钮 (ST.D/R)
- [11] TH.D/R, to adjust the D/R for throttle channel  
油门通道舵量调节旋钮 (TH.D/R)
- [12] Toggle Switch, to set the related function of ESC.  
拨码开关 (切换电调的工作模式)
- [13] TH.REV, Throttle Channel Reverse Button  
油门通道反向开关 (TH.REV)
- [14] G.LED, Status Indicator  
状态指示灯绿色 LED (G.LED)
- [15] BIND Button  
对码按键 (BIND)
- [16] ST.TRIM, to adjust the trim of steering channel.  
方向通道微调旋钮 (ST.TRIM)
- [17] TH.TRIM, to adjust the trim of throttle channel.  
油门通道微调旋钮 (TH.TRIM)
- [18] POWER ON/OFF, Power Switch  
电源开关 (POWER OFF/ON)

## Overview 接收机

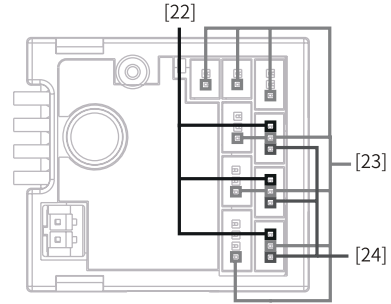
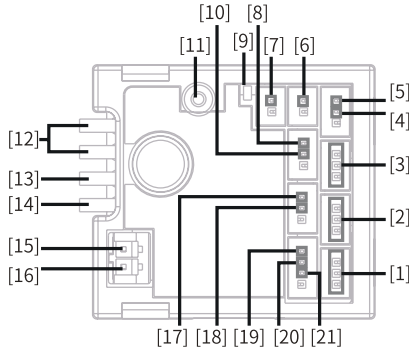

- |                                       |                            |   |
|---------------------------------------|----------------------------|---|
| [1] CH1                               | [9] LED                    | [17] Left Turn Signal Light Interface         |
| [2] CH3                               | [10] Headlight interface   | [18] Right Turn Signal Light Interface        |
| [3] CH4                               | [11] Antenna               | [19] Tail Light Interface                     |
| [4] Headlight Interface               | [12] Power Switch          | [20] Brake Light Interface                    |
| [5] Right Turn Signal Light Interface | [13] Battery Line Anode    | [21] Backup Light Interface                   |
| [6] Fog Light Interface               | [14] Battery Line Ccathode | [22] Signal Pin                               |
| [7] Fog Light Interface               | [15] Motor Interface "M+"  | [23] + (CH Interface/Light Interface Anode)   |
| [8] Left Turn Signal Light Interface  | [16] Motor Interface "M-"  | [24] - (CH Interface/Light Interface Cathode) |

- |           |             |                |            |
|-----------|-------------|----------------|------------|
| [1] CH1   | [7] 雾灯接口    | [13] 电池线正极     | [19] 尾灯接口  |
| [2] CH3   | [8] 左转灯接口   | [14] 电池线负极     | [20] 刹车灯接口 |
| [3] CH4   | [9] LED 指示灯 | [15] 马达接口 "M+" | [21] 倒车灯接口 |
| [4] 前灯接口  | [10] 前灯接口   | [16] 马达接口 "M-" | [22] 通道信号端 |
| [5] 右转灯接口 | [11] 天线     | [17] 左转灯接口     | [23] 电源正极  |
| [6] 雾灯接口  | [12] 电源开关   | [18] 右转灯接口     | [24] 电源负极  |

\* Note: CH1, CH3 and CH4 interfaces use standard 1.25mm\*3Pin terminal blocks. The car light interface uses standard 1.25mm terminal blocks. The battery interface uses an Molex 51005 female connector. The motor interface is a PH2.0 female terminal blocks.

\* 注: CH1 通道、CH3 通道和 CH4 通道接口采用标准的 1.25mm\*3Pin 端子座; 车灯接口采用标准的 1.25mm 端子座; 电池接入采用 Molex 51005 母座接口; 马达接口采用 PH2.0 母座端子座。

## Receiver LED 接收机指示灯

The LED status indicates the power supply state of the receiver and its working state.

Off: The receiver is not powered on.

Solid on in red: The receiver is connected to the power supply. It works normally.

Fast flashing: The receiver is in the bind mode.

Slow flashing: The LED flashes slowly when the transmitter is powered off, unbound, or no signal.

接收机状态指示灯用于指示接收机的电源及工作状态。

灭: 接收机电源未接通。

红灯常亮: 接收机已连接电源, 并正常工作。

快速闪烁: 接收机处于对码状态中。

慢速闪烁: 发射机未开机或未对码, 无信号情况。

### Transmitter Battery Installation 发射机电池安装

Before operation, install the battery and connect the system as instructed below.  
开始操作前，请按照本章的顺序和指引安装电池、连接设备。

**Danger** 危险 Only use specified battery (X4 AAA batteries).  
仅使用厂家指定的电池。

**Danger** 危险 Do not open, disassemble, or attempt to repair the battery.  
请勿打开、拆卸或自行维修电池。

**Danger** 危险 Do not crush/puncture the battery, or short the external contacts.  
请勿挤压、刺穿或接触电池的金属端子。

**Danger** 危险 Do not expose to excessive heat or liquids.  
请勿将电池置于高温环境或液体中。

**Danger** 危险 Do not drop the battery or expose to strong shocks or vibrations.  
请注意防止电池跌落、碰撞或振动。

**Danger** 危险 Always store the battery in a cool, dry place.  
请将电池存放在干燥阴凉的环境中。

**Danger** 危险 Do not use the battery if damaged.  
如果电池损坏，请立即停止使用。

Battery Type: AAA

Follow the steps below to install the batteries:

1. Open the battery compartment cover.
2. Insert 4 AAA batteries with the correct polarity. Make sure it is connected with the correct polarity to avoid damage.
3. Replace battery compartment cover.

Low battery alarm: When the battery is lower than 4.2V, the transmitter will give a alarm with the LED flashing slowly.

\*Note: When installing the batteries, be careful to handle the positive and negative poles. (As shown in the picture on the right)

电池类型使用：AAA 电池

请按照以下步骤安装发射机电池：

1. 打开电池仓盖。
2. 将 4 颗电量充足的 AAA 电池装入电池仓内，注意正负极方向并确保电池上的金属端子与电池仓内的金属端子接触。
3. 盖好电池仓盖。

低电量报警：当电量低于 4.2V 时，发射机即发出声音报警同时 LED 慢闪

\*注：安装电池时，请留意电池正负极，避免安装错误。（如右图所示）

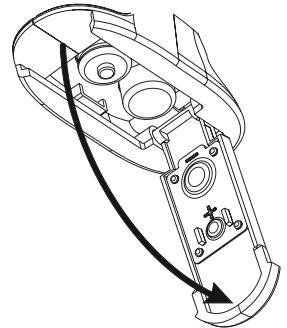

**Receiver and Servo Installation 接收机与舵机安装**

Make sure that the receiver is mounted in an appropriate location within the model, to ensure a stable signal, maximum range and to mitigate external interference, follow these guidelines:

Pay attention to the following when installing the receiver:

1. "Make sure the receiver is not installed near motors or sources of electrical noise.
2. Keep the receivers antenna away from conductive materials such as carbon or metal. To ensure normal function, make sure there is a gap of at least 1cm between the antenna and the conductive material.

请结合相应模型的结构选择合适的位置安装接收机，同时为了确保接收机的性能和遥控距离的稳定，并防止外界干扰，请注意以下操作事项：

1. 确保接收机安装在远离电机，电子噪声过多的区域。
2. 接收机天线需远离导电材料，例如金属棒和碳纤维物质。为了避免影响正常工作，请确保接收机和导电材料之间至少有 1 厘米以上的距离。



**Caution**  
小心

To prevent damage do not power on the receiver during installation.  
准备过程中，请勿连接接收机电源，避免造成不必要的损失。

**Instructions 操作指引**

After setting up, follow the instructions below to operate the system.

准备操作完成后，您可以按照本章指引开始使用本产品。

**Power On 开机**

Follow the steps below to turn on the transmitter:

1. Check to make sure that that battery is fully charged and installed correctly.
  2. Toggle the switch to the [ON] position. When active the R.LED will be lit.
  3. Connect the receiver to power.
- For safety always power on the transmitter before the receiver.

请按照以下步骤进行开机：

1. 检查系统状态，确保电池电量充足且安装正确。
  2. 将电源开关拨到 [ON] 位置，R.LED 灯常亮。
  3. 连接接收机电源。
- 为保障模型及人员安全，使用时请先打开发射机再给接收机上电



**Note**  
警告

Operate with caution in order to avoid damage or injury.  
此时系统已启动，请谨慎操作，否则可能导致产品损坏或人员伤亡。



**Note**  
警告

Make sure that the throttle trigger is at its neutral position and the switches are set to their proper position.  
为了您的安全请将发射机开关和油门打到安全位置。

## LED Indicator LED 指示

1. R.LED: The red power indicator;
2. G.LED: The green status indicator;
3. RX.BATT: ESC battery power indicator.
  - When the power is high, the RX.BATT LED will be solid on in green.
  - When the power is medium, the RX.BATT LED will be solid on in orange.
  - When the power is low, RX.BATT LED will be solid on in red.
  - When the power is ultra low, the RX.BATT LED will be flash slow in red.
  - When the receiver is not connected, "the RX.BATT LED will maintain the last indicated state.

1. R.LED: 红色电源指示灯;
2. G.LED: 绿色状态指示灯;
3. RX.BATT: 电调电池电量指示灯
  - 电量高: 指示灯绿色常亮
  - 电量中: 指示灯橙色常亮
  - 电量低: 指示灯红色常亮
  - 电量过低: 指示灯红色慢闪
  - 接收机掉码: 指示灯保持最后的指示状态

## Binding 对码

The transmitter and receiver have already been bound at the factory.

However if the receiver needs to be replaced or additional receivers bound follow these steps:

1. Turn on the transmitter while holding the bind button to enter bind mode. G.LED will start flashing quickly.
    - Once in bind mode release the bind button.
  2. The receiver will power on and wait for 1 second ,if without connection, it will enter the matching code automatically;
  3. Once the binding is successful, the receiver LED and the G.LED of the transmitter will be solid on.
- \*Note: When binding, put the transmitter into bind mode first, then the receiver. If the binding is not completed within ten seconds, the LED of the receiver will enter its slow flashing state.

发射机和接收机在出厂前已对码成功。

如需更换其他的发射机或接收机, 请按照如下步骤进行对码:

1. 将发射机按住对码按键 (BIND) 开机即进入对码状态, 此时 G.LED 快闪, 松开对码按键;
2. 接收机上电等待 1 秒没有连接即自动进入对码状态;
3. 对码成功后, 接收机及发射机指示灯常亮;

\*注: 对码时请先将发射机进入对码状态, 再将接收机进入对码状态; 若 10 秒内对码没有完成, 接收机 LED 指示灯进入慢闪状态。

## Instructions 操作指引

### Stick Calibration 摇杆校准

This function is used to set the neutral position for throttle and wheel.

Every transmitter is calibrated before leaving the factory, however if recalibration is required, please follow these steps:

1. Turn and hold the wheel as far clockwise as it will turn, hold the throttle all the way forward, then turn on the transmitter in calibration mode.
  - The R.LED and G.LED will flash twice.
  - The RX.BATT LED will be solid on in yellow.
2. Calibrate steering wheel: Turn the steering wheel to max and min travel point in clockwise and counterclockwise.
  - The R.LED will be off.
  - The RX.BATT LED will be solid on in red.
3. Throttle trigger calibration: Push/pull the throttle trigger to forward/backward as far as it will go.
  - When the calibration is completed, the G.LED will be off.
  - The RX.BATT LED will be solid on in green.
4. Both steering wheel and throttle trigger have finished the calibration.
  - The RX.BATT LED will be off.
5. Once the calibration is finished, press the BIND button to save and exit.

该功能可以用于方向手轮和油门扳机的中位角度修正。

发射机在出厂前已校准完成，如需要重新校准，请按照以下步骤执行。

1. 同步将手轮顺时针打到最大、扳机往前推到底并开机，进入校准模式功能；
  - R.LED 指示灯和 G.LED 指示灯二闪一灭
  - RX.BATT 指示灯黄色常亮
2. 方向手轮校准:将手轮顺时针和逆时针转到最大最小；
  - R.LED 指示灯灭
  - RX.BATT 指示灯红色常亮
3. 油门扳机校准: 将扳机向前向后推到最大和最小；
  - G.LED 指示灯灭
  - RX.BATT 指示灯绿色常亮
4. 方向手轮油门扳机均校准通过；
  - RX.BATT 指示灯灭
5. 校准完成后按“BIND”键退出并保存数据。

### Power Off 关机

Follow the steps below to turn off the system:

1. Disconnect the receiver power.
2. Toggle the transmitter's power switch to the off position.

请按照以下步骤进行关机：

1. 断开接收机电源；
2. 将电源开关拨到 [OFF] 位置，使发射机关闭。



Make sure to disconnect the receiver power before turning off the transmitter. Failure to do so may lead to damage or serious injury.  
关闭时，请务必先关闭接收机电源，再关闭发射机，否则可能导致模型损坏、人员受伤。

## Channel Description 通道说明

The transmitter outputs a total of 4 channels, which are assigned as below, as well as the functions.

- CH1 Channel: The assigned control is the steering wheel. CH1 controls the steering to enable a car to turn left or right.
- CH2 Channel: The control is the throttle trigger. CH2 controls the throttle to enable a car to move forward or backward.
- CH3 Channel: The control is the CH3 three-position switch. Users can customize the channel function. For example, function as a fast /slow-position servo channel.
- CH4 Channel: The control is the CH4 button switch. Users can customize the channel function. For example, control the car lights (short-press to switch the car light mode), and switch the drive control/ four-wheel steeringfunction.

该发射机共输出 4 个通道，控件分配和相应功能如下：

- CH1 通道：控件为方向手轮，功能为方向，控制车子左右转向。
- CH2 通道：控件为油门扳机，功能为油门，控制车子前后行驶。
- CH3 通道：控件为 CH3 三档开关，可自定义通道功能，如可作为快慢档舵机通道。
- CH4 通道：控件为 CH4 按键开关，可自定义通道功能，如可控制车灯（短按切换车灯工作模式）、可切换驱动控制 /四轮转向功能。

## Channel Reverse 通道反向

This function is used to adjust the action direction of the servo or motor

The ST.REV / TH.REV switches are the reverse buttons for CH1 and CH2. If the switch is up it indicates reverse, and the down indicates normal.

该功能用于调整通道的动作方向。

旋钮 ST.REV/TH.REV 分别为 CH1、CH2 通道反向按键，开关上拨表示反向，下拨表示正常。

## Trims 微调

The ST.TRIM switch is used to adjust the trim for CH1 (steering), and can also adjust the trim for CH3 as multiplexing mode. The TH.TRIM switch is used to adjust the trim for CH2(throttle), and can also adjust the trim for CH4.

Refer to [Mode Switching] for multiplexing switching mode.

ST.TRIM/TH.TRIM: Counterclockwise adjustment to increase the trim value. The maximum value is 120us.

ST.TRIM/TH.TRIM: Clockwise adjustment to decrease the trim value. The minimum value is -120us.

Note: After the throttle trim is changed, the receiver needs to be re-powered on to recognize the new throttle neutral. Otherwise, an exception may occur during vehicle reversing.

ST.TRIM 为 CH1 方向微调，可复用为 CH3 通道微调；

TH.TRIM 为 CH2 油门微调，可复用为 CH4 通道微调；

以上具体复用切换方式见 [模式切换]。

调节范围：-120us ~ +120us；

ST.TRIM/TH.TRIM：逆时针调节，增大微调值，最大为 120us；

ST.TRIM/TH.TRIM：顺时针调节，减少微调值，最小为 -120us。

注：CH2 油门微调调整后，接收机须重新通电以识别新的油门中位，否则可能会出现倒车异常的现象。

## D/R 舵量调节

The ST. D/R switch is used to adjust the servo travel amount CH1(Steer Trim), and can also adjust the travel amount for CH3 as multiplexing mode.

The TH.D/R switch is used to adjust the servo travel amount for CH2(throttle), and can also adjust the travel amount for CH4 as multiplexing mode.

Refer to [Mode Switching] for multiplexing switching mode.

Adjustment range: 0-120%;

ST.D/R: Counterclockwise adjustment to increase the servo travel amount. The maximum value is 120%.

ST.D/R: Clockwise adjustment to decrease the servo amount. The minimum value is 0%.

TH.D/R: Counterclockwise adjustment to increase the servo amount. The maximum value is 120%.

TH.D/R: Clockwise adjustment to decrease the servo amount. The minimum value is 0%.

ST.D/R 为 CH1 方向舵量调节, 可复用为 CH3 舵量调节;

TH.D/R 为 CH2 油门舵量调节, 可复用为 CH4 舵量调节;

调节范围: 0 ~ 120%;

ST.D/R: 逆时针调节, 增加舵量, 最大为 120%;

ST.D/R: 顺时针调节, 减小舵量最小为 0%。

TH.D/R: 逆时针调节, 增加舵量, 最大为 120%;

TH.D/R: 顺时针调节, 减小舵量最小为 0%。

## Mode switching 模式切换

This function is for reusing the ST.TRIM and ST.D / R buttons for different channels setting:

Under normal power-on condition, press the BIND button twice (within 1S) to switch between mode 1 and mode 2. By default, mode 1 is used.

Mode 1: R.LED is always on. G.LED is off. ST.TRIM is for CH1 trim. ST.D/R is for CH1 ser vo adjustment . TH.TRIM is for CH2 throttle trim. TH.D/R is for CH2 throttle ser vo adjustment .

Mode 2: R.LED and G.LED are flashing alternately. ST.TRIM is for CH3 trim. ST.D/R is for CH3 ser vo adjustment . TH.TRIM is for CH4 trim. TH.D/R is for CH4 ser vo adjustment .

此功能用于将 ST.TRIM 及 ST.D/R 旋钮复用于 CH3、CH4 通道 (详见 [微调]、[舵量调节] )。

功能设置:

正常开机状态下快速短按两下对码按键 (BIND) (1 秒内) 即可循环切换模式一、二, 开机默认为模式一。

模式一: R.LED 指示灯常亮, G.LED 示灯不亮, ST.TRIM 调节 CH1 微调, ST.D/R 调节 CH1 舵量;

TH.TRIM 调节 CH2 油门微调, TH.D/R 调节 CH2 油门舵量;

模式二: R.LED 指示灯和 G.LED 指示灯交替闪烁, ST.TRIM 调节 CH3 微调, ST.D/R 调节 CH3 舵量;

TH.TRIM 调节 CH4 微调, TH.D/R 调节 CH4 舵量。

## Failsafe 失控保护

The failsafe function is used to protect the model and personnel when the receiver is out-of-control. The failsafe for CH2 is enabled by default, the ESC1 will enter the brake state when the receiver is out-ofcontrol. By default, the failsafe for CH1, CH3 and CH4 channels have not set, and can be set at the transmitter side, and these three channels will maintain the last output in case of out-of-control.

Setup:

In the normal power-on state, set the control corresponding to the channel to be configured with failsafe to the preset position, meanwhile, press and hold the BIND button for 3 seconds to set the output value as the failsafe value. And if the G.LED flashes for 2 seconds, it indicates that the setting is successful.

Then the failsafe value set will output in case of out-of-control.

## System Functions 系统功能

此功能用于当接收机无法正常收到发射机的信号不受控制时，保护模型和操作人员的安全。

接收机 CH2 通道默认开启失控保护，失控后电调进入刹车模式；而 CH1 通道、CH3 通道和 CH4 通道，可在发射机端设置相应的失控保护值。默认未设置，未设置时 PWM 接口保持最后输出。

功能设置：

发射机开机正常通信状态下，将需要设置的通道保持在需要设定的失控保护值位置保持不动，同时长按对码键 (BIND) 3 秒，G.LED 指示灯闪烁 2 秒表示设置成功，即当接收机无法接收信号后，将按照设定的失控值输出。

### Beginner Mode 初学者模式

Beginner mode is designed for people new to the hobby.

In this mode the throttle channel has been limited to output 50 percent, the channel range defaults has been set to 1250~1500~1750us. By default, the mode is normal mode.

Setup:

To switch between beginner mode and normal mode, press and hold the CH4 button while turning the steering wheel completely counterclockwise as far as it can, and at the same time, power on the transmitter. When the G.LED works in two-flash-one-off mode for 3 seconds, then the beginner mode has switched. In case of the G.LED is off, the normal mode is switched.

此初学者模式比较适合入门级玩家，通过对油门幅度的控制来提高操作的安全性。

初学者模式油门输出仅为 50%，即 CH2 通道范围默认为 1250~1500~1750us。出厂默认为正常模式。

功能设置：

切换初学者模式和正常模式：按住 CH4 按键，同时将方向手轮逆时针打到底，并开机，当 G.LED 指示灯二闪一灭持续 3 秒时，表明切换到初学者模式；正常模式时，G.LED 指示灯灭。

### Four-wheel Steering 四轮转向

The transmitter supports four-wheel steering function which is used to set the wheels that control the steering of the vehicle. This function adapts partial crawler types with steering on both front and rear wheels.

The four-wheel steering function is controlled by CH4 channel, and the control is CH4 button. Switch to four-wheel steering function firstly, then set the control mode.

#### Switching the drive control/four-wheel steering function

In the normal power-on state, press both the BIND button and the CH4 button to switch between the drive control and four-wheel steering. The drive control is the default mode.

Note: The setting will be save when the transmitter turns off.

After switching to four-wheel steering function, you can set the control mode in turn: Front wheel steering, front and rear wheels reversal steering, front and rear wheels in the same steering, rear wheel steering (normal) and rear wheel steering (reverse).

Setup:

Press and hold the CH4 button over 2 seconds to switch the mode. Switch one mode per press of the control. By default, it is front wheel steering.

支持四轮转向模式设置，用于设置控制车辆转向的车轮，适用于前后轮均带转向功能的部分攀爬车类型。

四轮转向模式复用 CH4 通道，由 CH4 按键控制。要设置四轮转向控制方式，需先切换到四轮转向模式。

驱动控制模式 / 四轮转向模式切换

发射机正常开机状态下，同时短按 BIND 按键和 CH4 按键，即可切换驱动控制模式和四轮转向模式，默认驱动控制模式。

注：模式切换后，关机保存设置。

切换到四轮转向模式后，可顺序设置五种转向控制方式：仅前轮转向、前后反向、前后同向、仅后轮转向（正向）和仅后轮转向（反向）。

功能设置：长按 CH4 按键（≥ 2 秒）切换模式。每长按控件一次切换一种模式。默认前轮转向。

## Drive Control 驱动控制

The transmitter supports drive control function which is used to set drive control mode. The drive function is controlled by CH4 channel, and the control is CH4 button. Switch to drive control function firstly, then set the control mode.

**Switching the drive control/four-wheel steering function**

In the normal power-on state, press both the BIND button and the CH4 button to switch between the drive control and four-wheel steering. The drive control is the default mode.

Note: The setting will be save when the transmitter turns off.

After switching to drive control function, you can set the drive mode between 2-wheel drive and 4-wheel drive.

Setup:

Press and hold the CH4 button over 2 seconds to switch the mode. Switch one mode per press of the control.

支持驱动模式设置，用于设置驱动控制模式。

驱动模式复用 CH4 通道，由 CH4 按键控制。要设置驱动控制方式，需先切换驱动控制模式。

驱动控制模式 / 四轮转向模式切换

发射机正常开机状态下，同时短按 BIND 按键和 CH4 按键，即可切换驱动控制模式和四轮转向模式，默认驱动控制模式。









注：模式切换后，关机保存设置。

切换到驱动模式后，可设置为两驱控制或四驱控制。

功能设置：

长按 CH4 按键（≥ 2 秒）切换模式。每长按控件一次切换一种模式。

## ESC Parameters Setting 电调参数设置

Running Mode	Battery Type	Drag Brake	
 FWD/REV/BRK	 Lipo	 0%	 75%
 FWD/REV	 NiMH	 50%	 100%

## Toggle Switch Sign 拨码开关标识

The Toggle Switch on the transmitter is used to set ESC parameters, that is, the Toggle Switch is located at different positions and the corresponding parameter values are different.

There are three parameters can be set for the ESC, which are "Running Mode", "Battery Type" and "Drag Brake". There are slide switches numbered 1, 2, 3, 4 on the transmitter panel. The above parameters can be set by toggling up and down.

发射机上的拨码开关用于设置电调参数，即拨码开关位于不同位置对应参数值不同。

该电调有三个参数项可以设置，分别是“运行模式 (Running Mode)”、“电池类型 (Battery Type)”、“拖刹力度 (Drag Brake)”。发射机面板上有一列编号为 1 2 3 4 的拨码开关，通过上下拨动可以实现对上述参数项的设置。

## 1. Running Mode

FWD/REV/BRK(Forward/Reverse/Brake): This mode adopts "double click" reverse mode, that is, when the throttle trigger is pushed from natural range to the reverse area for the first time, the motor is only braking and will not reverse; when the throttle trigger is moved back to the natural range and pushed to the reverse area for the second time, it will reverse. This mode is applicable to general models.

FWD/REV(Forward/Reverse): This mode adopts "one click" reverse mode, that is, when the throttle trigger is pushed from natural range to the reverse area, the motor immediately generates reverse action, which is generally applied to rock crawler.

**Setup:**

Toggle the No. 1 slide switch to the down, then the running mode is set to FWD / REV / BRK. Toggle the No. 1 slide switch to the up, then the running mode is set to FWD/REV.

**Battery Type**

There are LiPo and NiMH cells. It can be set according to the actual use.

**Setup:**

Toggle the No. 2 slide switch to the down, then the battery type is set to Lipo. Toggle the No. 2 slide switch to the up, then the battery type is set to NiMH.

**Drag Brake Force**

The drag brake means that when the throttle trigger moves from the forward or reverse area to neutral range, it will produce certain braking force to the motor, the larger the value is, the greater the drag brake force is. Select proper braking force according to the actual situation.

**Setup:**

Toggle both the No. 3 and the No.4 slide switches to the down, then the drag brake force is set to 0%. Toggle the No. 3 slide switch to the down and the No.4 slide switch to the up, then the drag brake force is set to 50%. Toggle the No. 3 slide switch to the up and the No.4 slide switch to the down, then the drag brake force is set to 75%. Toggle both the No. 3 and the No.4 slide switches to the up, then the drag brake force is set to 100%.

**运行模式 (Running Mode)**

前进后退带刹车 (FWD/REV/BRK)：此模式采用的是“双击式倒车”，即油门扳机在第一次从中点区域推至反向区域时，电机只是刹车，不会产生倒车动作；当油门扳机回到中点区域并第二次推至反向区域时，则产生倒车动作。此模式适用于一般车型。

直接正反转 (FWD/REV)：此模式采用“单击式”倒车方式，即油门扳机从中点区域推至反向区域时，电机立即产生倒车动作，该模式一般用于攀爬车等特种车辆。

**功能设置：**

将发射机面板上编号为 1 的拨码开关拨至下，运行模式即设置为前进后退带刹车 (FWD/REV/BRK)。将发射机面板上编号为 1 的拨码开关拨至上，运行模式即设置为直接正反转 (FWD/REV)。

**电池类型 (Battery Type)**

有锂电和镍氢两种选择，根据实际使用情况设置即可。

**功能设置：**

将发射机面板上编号为 2 的拨码开关拨至上，电池类型即设置为锂电池。将发射机面板上编号为 2 的拨码开关拨至下，电池类型即设置为镍氢。

**拖刹力度 (Drag Brake)**

拖刹是指当油门扳机从正向区域或反向区域转入中点区域内时，对电机产生一定的刹车力，这样可以模拟有刷电机的碳刷对电机转子的阻力，适合减速入弯及攀爬车应用。

**功能设置：**

将发射机面板上编号为 3 的拨码开关和编号为 4 的拨码开关拨至下侧，拖刹力度即设置为 0%；将发射机面板上编号为 3 的拨码开关拨至下侧，编号为 4 的拨码开关拨至上侧，拖刹力度即设置为 50%；将发射机面板上编号为 3 的拨码开关拨至上侧，编号为 4 的拨码开关拨至下侧，拖刹力度即设置为 75%；将发射机面板上编号为 3 的拨码开关和编号为 4 的拨码开关拨至上侧，拖刹力度即设置为 100%。

## Function Instructions 功能说明

### Attentions 注意事项

- Make sure the product is installed and calibrated correctly, failure to do so may result in serious injury.
- Please carefully check each power device and car frame instructions to ensure the power matching is reasonable before use. Avoid damaging power system due to incorrect matching.
- Do not let the external temperature of the system exceed  $90^{\circ}\text{C} / 194^{\circ}\text{F}$ , because high temperature will damage the power system.
- Make sure the receiver's battery is disconnected before turning off the transmitter, failure to do so can result out of control. Unreasonable setting of the Failsafe may cause accidents.
- After use, remember to disconnect the battery and the ESC. If the battery isn't disconnected, the ESC will consume electric energy all the time even if it is off. It will discharge completely if connect the battery for a long time, thus resulting in the failure of the battery or the ESC. We are not responsible for any damage caused by this!
- Make sure the receiver is mounted away from motors or any device that emits excessive electrical noise.
- Keep the receiver's antenna at least 1cm away from conductive materials such as carbon or metal.
- Do not power on the receiver during the setup process to prevent loss of control.
- If the throttle trim is changed on the transmitter side, the receiver needs to be re-powered to recognize the new throttle neutral. Otherwise, an exception may occur during vehicle reversing.
- 使用前必须确保本产品与模型安装正确, 否则可能导致模型发生严重损坏。
- 请查看各动力设备以及车架说明书, 确保动力搭配合理, 避免因错误的搭配导致动力系统损坏。
- 勿使系统的外部温度超过  $90^{\circ}\text{C} / 194^{\circ}\text{F}$ , 高温将会毁坏动力系统。
- 关闭时, 请务必先关闭接收机电源, 然后关闭发射机。如果关闭发射机电源时接收机仍然在工作, 将导致遥控设备失控。失控保护设置不合理可能引起事故。
- 用完完后, 若长时间不玩车, 切记断开电池与电调的连接。如电池未断开, 即使电调开关处于关闭状态, 电调也会一直消耗电能 (只是非常小), 长时间连接电池最终会被过放, 进而导致电池或电调出现故障。我们不对因此而造成的任何损害负责!
- 确保接收机安装在远离电机或电子噪声过多的区域。
- 接收机天线需远离导电材料, 例如金属棒和碳物质。为了避免影响正常工作, 请确保接收机天线和导电材料之间至少有 1 厘米以上的距离。
- 准备过程中, 请勿连接接收机电源, 避免造成不必要的损失。
- 若在发射机端调整油门微调后, 接收机须重新通电以识别新的油门中位, 否则可能会出现倒车异常的现象。

### Protect Function 保护功能

- The receiver supports low voltage protection and high voltage protection function.
- Low Voltage Protection: When the receiver enters the low voltage protection state in case of detecting low voltage, CH2 motor channel has no output. Channels of CH1, CH3 and CH4 output normally, and all the lights flash slowly for prompt.
  - High Voltage Protection: When the receiver enters the high voltage protection state, all channels have no output. All car lights flash quickly for prompt.
- The receiver supports the overheating protection and the blocking protection function.
- Overheating Protection: The receiver will enter the overheating protection state in case of the high internal temperature of the ESC, the CH2 motor channel won't output, but the other channels will output normally. All car lights flash quickly for prompt. The CH2 motor channel will output normally when the temperature is normal.
  - Blocking Protection: When the external motor is blocked, it enters the blocking protection state, to protect the ESC and the motor. The CH2 motor channel won't output, but the other channels will output normally. The CH2 motor channel will output normally when there is no blocking.

## Function Instructions 功能说明

本接收机具有电池电压过低和过高保护功能。

- 电压过低保护：当检测到电池电压过低时，CH2 马达通道无输出，CH1 通道、CH3 通道、CH4 通道正常输出，所有车灯慢闪提示。
- 电压过高保护：当检测到电池电压过高时，所有通道无输出，所有车灯快闪提示。

本接收机电调具有过热保护和堵转保护功能。

- 过热保护：当检测到整机温度过高时，CH2 马达通道无输出，CH1 通道、CH3 通道、CH4 通道正常输出，所有车灯快闪提示；当温度正常后，CH2 马达通道恢复输出。
- 堵转保护：当外部马达堵转时，进入堵转保护状态，用于保护电调和马达，CH2 马达通道无输出，CH1 通道、CH3 通道、CH4 通道正常输出；待无堵转时，CH2 马达通道恢复正常输出。

### Car Light Control 车灯控制

The car light control is mainly to implement the changeover of lighting states and lighting modes by the setting of the transmitter. All car lights will be on for 1second as the self-check display when the receiver is powered on.

(The following is the output function of the built-in light control in the receiver. There may be differences in the factory settings for each RC model vehicle.)

This receiver is preset with five modes for controlling model car lights. In each mode, the on/off states of backup lights are consistent; in other words, the backup light is in solid on state when the model car backs up.

Otherwise, it is in off state. The turn signal light, headlight and roof light have different on/off states as follows.

- Default mode: In this mode, the turn signal light is in off state regardless of whether the model car makes a turn or not; When backing up, the backup light is in solid on state, and otherwise, it is in off state; The headlight and roof light are in off state.
- Mode A: In this mode, the turn signal light is in a slow flashing state when the model car makes a turn; When backing up, the backup light is in solid on state, and when not backing up, it is in off state; The headlight and roof light are in a low-light state.
- Mode B: In this mode, the turn signal light is in a slow flashing state when the model car makes a turn; When backing up, the backup light is in solid on state, and when not backing up, it is in off state; The headlight and roof light are in high-light state.
- Mode C: In this mode, the turn signal light is in a continuously slow flashing state regardless of whether the model car makes a turn or not; When backing up, the backup light is in solid on state, and when not backing up, it is in off state; The headlight and roof light are in high-light state.
- Mode D: In this mode, the turn signal light is in a slow flashing state when the model car makes a turn; When backing up, the backup light is in solid on state, and when not backing up, it is in off state; The headlight and roof light are in off state.

Notes:

1. Press the CH4 button of the transmitter to switch the working mode, one mode per press (Default Mode, Mode A, Mode B, Mode C and Mode D are switched in turn).
2. Every time the receiver is turned on, the car light control mode is in Default Mode.
3. Mode C is an emergency light working state. In this mode, the left and right turn signal lights flash synchronously and slowly as emergency lights.
4. This receiver identifies the neutral positions of Steering CH1 and Throttle CH2 automatically when it is powered on. It recommends to power on the receiver again after the trims of the transmitter are adjusted.

## Function Instructions 功能说明

车灯控制主要是通过发射机的设置实现车灯亮灯状态及亮灯模式的转换。接收机上电开机瞬间所有车灯长亮 1 秒做自检显示。(以下为接收器内置灯控的输出功能,每款模型车出厂设置会有差异。)

本接收机对模型车车灯的控制预设了五种模式,各模式下模型车的倒车灯亮灭状态一致,即当模型车倒车时,倒车灯为常亮状态,反之则为常灭状态。而转向灯、前灯和车顶灯的亮灭状态各异,具体如下所述:

- 默认模式:此模式下,无论模型车是否转弯,转向灯状态为常灭状态;当倒车时,倒车灯为常亮状态,反之则为常灭状态;前灯和车顶灯为常灭状态。
- 模式 A:此模式下,当模型车转弯时,转向灯为慢闪状态;当倒车时,倒车灯为常亮状态,非倒车时为常灭状态;前灯及车顶灯为低亮状态。
- 模式 B:此模式下,当模型车转弯时,转向灯为慢闪状态;当倒车时,倒车灯为常亮状态,非倒车时为常灭状态;前灯及车顶灯为高亮状态。
- 模式 C:此模式下,无论模型车是否转弯,转向灯为持续慢闪状态;当倒车时,倒车灯为常亮状态,非倒车时为常灭状态;前灯及车顶灯为高亮状态。
- 模式 D:此模式下,当模型车转弯时,转向灯为慢闪状态;当倒车时,倒车灯为常亮状态,非倒车时为常灭状态;前灯及车顶灯为常灭状态。

注:

1. 短按发射机上的 CH4 按键切换工作模式,每按一次,切换一个模式(默认模式、模式 A、模式 B、模式 C 和模式 D 依次切换);
2. 每次开机时,车灯控制模式为默认模式;
3. 模式 C 为应急灯工作状态,左右转向灯同时同步慢闪做应急灯;
4. 本接收机上电自动识别方向 CH1 和油门 CH2 的通道中位。当发射机调了微调后,建议重启一下接收机。

## ESC Function Instructions 电调功能使用说明

### Connect Related Equipments

Make sure the receiver is off before connection. Then connect the motor with M+ and M- of the receiver and connect the servo to the 3Pin interface("-", "+" and "S" are connected correspondingly). Finally, connect the battery to the power cable interfaces of the receiver correspondingly.

### Calibrate the Throttle Neutral Position

1. After connecting related equipment as above, turn on the transmitter first, then move the throttle trigger to the neutral position.
2. Turn on the switch of receiver at last. The receiver will automatically recognize the battery type when it is powered on again. Then it can run it.

Notes:

1. The ESC can be run after completing self-inspection (about 3 seconds) if power on, otherwise it cannot be operated normally.
2. If there is no power output, please check whether the throttle trim of the transmitter is set to the neutral position, the receiver will automatically recognize the neutral position of the trim throttle after restarting;
3. If the rotation direction is not correct during running, exchange the two cables connecting motor and receiver.
4. To make sure everything is ok, please turn on the transmitter first and then the receiver, and power off the receiver first and then the transmitter.

## Function Instructions 功能说明

### 连接相关设备

连接前请确认接收机电源开关处于关闭 (OFF) 状态, 将电机与接收机马达接口 M+/M- 相连接, 舵机接到接收机 3Pin 排针接口上 ("-"+"S" 相对应), 电池与电池线接口相接, 注意对应极性。

### 校准油门中点

1. 上面第一步相关设备连接好后, 先打开发射机, 并将发射机油门扳机置于中位位置 (自然状态);
2. 接收机通电, 待自动识别电池类型后方可运行。

注:

1. 电调功能必须等到自检完成后方可运行 (大约 3 秒), 否则可能无法正常动作;
2. 若开机后无动力输出, 请查看发射机油门微调是否置于中位位置, 接收机重启可自动识别微调油门中位;
3. 若运行时发现电机转向不对, 将接收机接电机的两根线互换位置即可;
4. 为了一切正常, 请养成先开发射机通电再接收机通电以及先接收机断电再关闭发射机的习惯。

### ESC Drag Brake Force 电调拖刹力度

The receiver supports the function of setting drag brake force at the transmitter side. Refer to ESC Parameters Setting for details.

本接收机支持在发射机端设置电调力度。功能设置请查看 [电调拖参数设置]。

### ESC Running Mode 电调运行模式

The receiver supports the function of setting running mode at the transmitter side. It can be set tow modes: FWD/REV and FWD/REV/BRK, and the default mode is FWD/REV/BRK, refer to 5.10 Parameter Setting for details.

本接收机支持在发射机端设置电调运行模式。可设置为直接正反转或正反转带刹车, 默认为正反转带刹车。功能设置请查看 [电调拖参数设置]。

### ESC Battery Type 电调电池类型

The receiver supports the function of setting battery type at the transmitter side. It can be set tow types: LiPo and NiMH, and the default type is LiPo, refer to Parameter Setting for details.

本接收机支持在发射机端设置电调电池类型。可设置为锂电池或镍氢电池, 默认为锂电池。功能设置请查看 [电调拖参数设置]。

### Failsafe 失控保护

The failsafe function is used to protect the model and personnel when the receiver is out-of-control. Refer to [Failsafe] for details.

此功能用于当接收机无法正常收到发射机的信号不受控制时, 保护模型和操作人员的安全。功能设置参考 [失控保护]。

## Product Specifications 产品规格

### Transmitter Specifications 发射机规格

Product : Model FS-MG41-BS	Life time : According to Battery Type
Channels : 4	Low Voltage Warning : <4.2V
Model Type : Car or Boat	Antenna Type : Single Built-in Antenna
RF : 2.4GHz ISM	Data Interface : None
Maximum Power : <20dBm (e.i.r.p.) (EU)	Temperature Range : -10 C ~ +60 C
2.4GHz Protocol : 2A-BS	Humidity Range : 20% ~ 95%
Resolution : 1024	Online Update : None
Input Power : 6V/DC or 1.5AAA*4	Dimensions : 118*73*145mm
Charging Interface : None	Weight : 130g
	Certifications : CE, FCC ID: N4ZMG400, MIC:R210-167762, IC: 25584-MG4BS00

产品型号 : FS-MG41-BS	续航时间 : 依电池类型
通道个数 : 4	低电压报警 : < 4.2V
适配模型 : 车、船	天线类型 : 内置单天线
无线频率 : 2.4GHz ISM	数据接口 : 无
发射功率 : <20dBm	温度范围 : -10°C ~ +60°C
无线协议 : 2A-BS	湿度范围 : 20% ~ 95%
通道分辨率 : 1024 级	在线更新 : 无
输入电源 : 6V DC 1.5AAA*4	外形尺寸 : 118mm*73mm*145mm
充电接口 : 无	机身重量 : 130g
	认证 : CE, FCC ID:N4ZMG400, MIC:R210-167762, IC:25584-MG4BS00

### Receiver Specifications 接收机规格

Product Model : FS-R4A1-BS	BEC Output : 6V/1A
Channels : 4	Data Output : PWM
Number of Lights : 7	Antenna : Single Built-in Antenna
Model Type : 1:18 Simulation Car, Crawler Car	Waterproof : PPX4
Applicable Motors : 180 Brushed Motor	Temperature Range : -10 C ~ +60 C
Input Power : NiMH (5~7Cell)/2S Lipo	Humidity Range : 20% ~ 95%
RF : 2.4GHz ISM	Online Update : None
Maximum Power : <20dBm (e.i.r.p.) (EU)	Dimensions : 33mm*30mm*12mm (Excluding capacitor)
2.4GHz Protocol : 2A-BS	Weight :11g
Resolution : 1024	Certifications : CE, FCC ID: N4ZR4A31, MIC: R210-177092,
Continuous / Peak Current : 10A/50A	IC: 25584-R4A31

## Product Specifications 产品规格

产品型号：FS-R4A1-BS	持续 / 峰值电流：10A/50A
通道个数：4	BEC 输出：6V/1A
车灯组数：7	数据输出：PWM
适配模型：1:18 仿真车、攀爬车	天线类型：内置单天线
适配电机：180 有刷电机	防水等级：PPX4
输入电源：NiMH (5~7Cell)/2S 锂电	温度范围：-10°C ~ +60°C
无线频率：2.4GHz ISM	湿度范围：20% ~ 95%
发射功率：<20dBm	在线更新：无
无线协议：2A-BS	外形尺寸：33mm*30mm*12mm (不含电容)
通道分辨率：1024 级	机身重量：11g 左右
	认证：CE, FCC ID: N4ZR4A31, MIC: R210-177092, IC: 25584-R4A31

## Vehicle Setup 车辆设置

### Charging the Battery 电池充电

Car Battery: 2S Lipo 7.4V 900mAh

Charger: USB balance charger, charging time 30-45 minutes.

1. Connect the USB port of the balance charger to a power source, and then connect the battery to the balance charger to start charging
2. When charging, the LED light will be red, and when charging is complete, the LED light will be green.
3. Do not charge unattended!
4. If you notice that the battery or charger is overheating, immediately disconnect the battery and charger, as this may be caused by an internal short circuit.

车用电池：2S Lipo 7.4V 900mAh

充电器：USB平衡充，充电时长30-45min。

- 1.将平衡充USB端口连接至电源，然后将电池连接至平衡充，充电开始。
- 2.充电时，LED灯状态为红色；充电完成时，LED灯状态为绿色。
- 3.请勿在无人看管的情况下进行充电！
- 4.如果发现电池或充电器过热，请立即断开电池和充电器，因为这可能是由内部短路引起的。

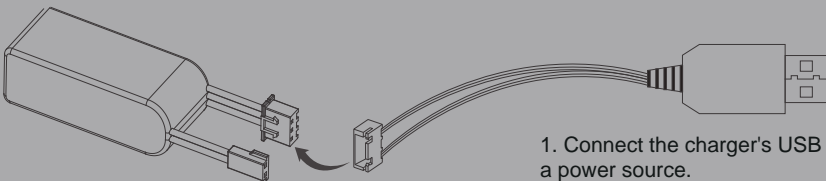

2. Connect the battery to the charger.  
2.将电池连接到充电器上。

1. Connect the charger's USB port to a power source.

- 1.将USB充电器端口连接到电源。

## Connecting the battery 连接电池

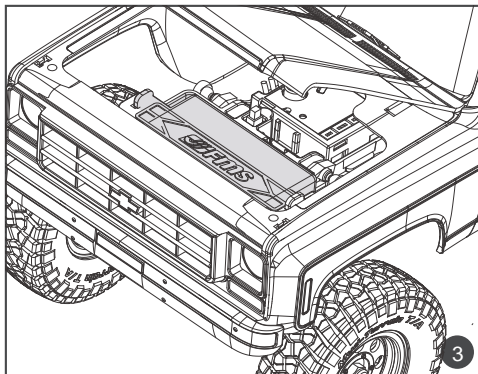
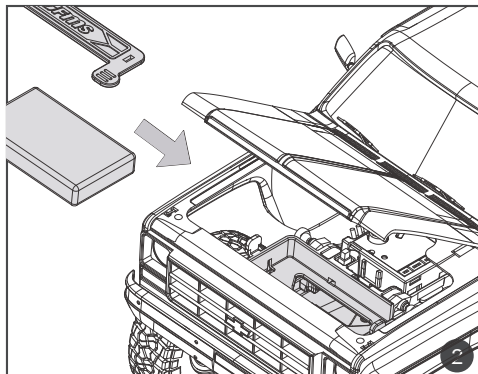
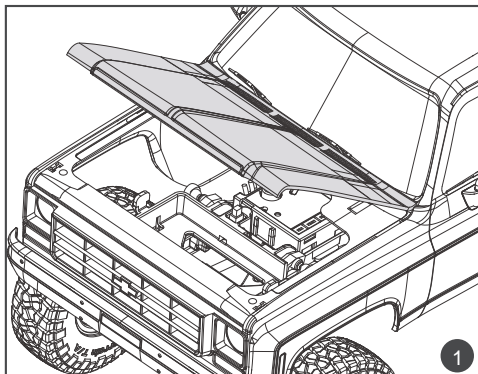

Open the engine hood as shown, load the battery into the battery compartment and secure it in place with the silicone strap. Connect the battery plug to the female connector of the receiver/ESC combo unit, and then close the engine hood.

The battery plug :51005 2P Male  
Battery compartment size: 43 x 19.8 x 12mm

如图所示，打开引擎盖，将电池放入电池舱并使用绑带固定；将电池插头连接到接收机/电调一体装置的母头，然后关闭引擎盖。

电池插头:51005 2P 公头

电池仓尺寸: 43 x 19.8 x 12mm



### NOTE 注意

1. If it is not in use for a long time, unplug and take off the battery to prevent battery leakage.
  2. The battery needs to be disconnected and take off from vehicle before it can be charged
  3. Do not open, disassemble, or attempt to repair the battery.
1. 如果长时间不使用本产品，请断开电池连接，并将电池取出，以防漏液。  
2. 给电池充电之前，请务必保证电池已断开连接，并已从车辆上取下。  
3. 不要打开、拆解或试图维修电池。

## Spare Parts List 配件列表

C2110	Hood red/white	引擎盖白红色
C2302	Hood black/red	引擎盖黑红色
C2303	Hood brown/white	引擎盖棕白色
C2304	Front and rear light cup set red	前/后灯杯组 红
C2305	Front and rear light cup set black	前/后灯杯组 黑
C2306	Front and rear light cup set brown	前/后灯杯组 棕
C2112	Hood mount set	引擎盖连接座
C2113	Rearview mirror and wiper	雨刮器及后视镜
C2114	Bumper	防撞
C2115	Lens	灯镜片
C2116	Body shell	车壳白红色
C2307	Body shell black/red	车壳黑红色
C2308	Body shell brown/white	车壳棕白色
C2117	Chassis red	底板红色
C2309	Chassis black	底板黑色
C2310	Chassis brown	底板棕色
C2118	Handle	手柄
C2311	Light set	灯线组
C2125	Window	车窗
C2126	Mirror lens	镜片
C3357	Tire	轮胎
C3356	Eight planets style wheels plastic parts B	八孔形状轮毂 B
C2295	motor set	电机套装
C2314	Screw set	螺丝套装
C2315V2	Front axle assembly V2	前桥总成 V2
C2258	Servo horn set	摇臂套装(黑色)
C2259	LiPo battery 2s 7.4V 900mAh	电池7.4V 2S 900mAh
C2261	MG41 transmitter V5	MG41 发射器 V5
C2262	R4A1 ESC/RX combo V5	R4A1 电调接收器 V5
C2263	MG41 + R4A1 transmitter receiver set V5	MG41 + R4A1 发射器/电调接收器 V5
C2316	Girder long version	长版金属大梁
C2264	Transmission gear box assembly	驱动牙箱成品
C3013	Transmission box shaft	齿轮箱传动轴
C3014	Transmission gear box plastic	传动箱胶件
C3015	Gear set	齿轮
C3018	Axle plastic parts	直桥胶件
C3019V2	Front portal axle cover V2	前门桥胶件 V2
C3020	C hub set	C座套件
C3021	Portal axle set	门桥轴
C3022	Rear wheel shaft set	后轮轴
C3023V2	Front dog bone set V2	狗骨 V2
C2268	Cvd axle set B	传动轴 B
C2317	rear axle assembly	后桥总成
C3027	Servo mount	舵机座
C3030	Pinion gear	电机齿
C3031	Wheel hex adaptor	六角接合件
C2272	Screw	螺丝套装
C3034	Screw nut	螺母
C3035	Steering servo	转向舵机
C3036	Variable speed servo	换挡舵机
C3039V2	Bearing set V2	五金轴承 V2
C3059V2	Portal axle metal gear V2	门桥金属齿轮 V2

## Spare Parts List 配件列表

C2269	Cvd axle set A	传动轴A
C3074	ball head screw	单球头螺丝
C3075	Double ball head screw	双球头螺丝
C3080	M4 aluminium ball head	M4铝波头
C2270	Shift lever	换挡拉杆
C3111	Servo saver set	转向舵机保护套装
C3060	All terrain wheel	全地形车轮成品
C3061	Metal differential	金属差速器
C3062	Metal transmission gear	变速箱金属齿
C2318	Metal rod set	金属拉杆
C3066	Metal drive gear	金属差速器驱动齿轮
C3110	Aluminum axle	铝合金直桥
C2267	Usb 2S lipo quick charger cable	USB 平衡充电器 7.4V 2000mA
C3134	Brass steering servo arm horn black	铜舵机臂黑
C3137	Portal axle cover set black	黄铜金属门桥黑 (套)
C2273	Oil shock absorbers assembly	避震器
C2275	Trailer hook	拖钩
C2276	Triangle pole	八字拉杆
C2277	Shock tower	避震架
C2319	Girder supporter and gear box mount	大梁接件及牙箱固定件
C2279	Battery box	电池座
C2320	Battery holder	电池硅胶带
C2323	Cockpit and driver a set	仿真驾舱及驾驶员A套装
C2324	Cockpit and driver b set	仿真驾舱及驾驶员B套装
C3344	Brass wheel counterweight	黄铜轮毂配重
C3306	Utility trailer A sliver	共用拖斗A 银
C3307	Utility trailer B sliver	共用拖斗B 银
C3308	Utility trailer C sliver	共用拖斗C 银
C3309	Utility trailer A black	共用拖斗A 黑
C3310	Utility trailer B black	共用拖斗B 黑
C3311	Utility trailer C black	共用拖斗C 黑
C3368	Wheel set	车轮组

EN:Oil Shock Absorbers Assembly

CN:避震

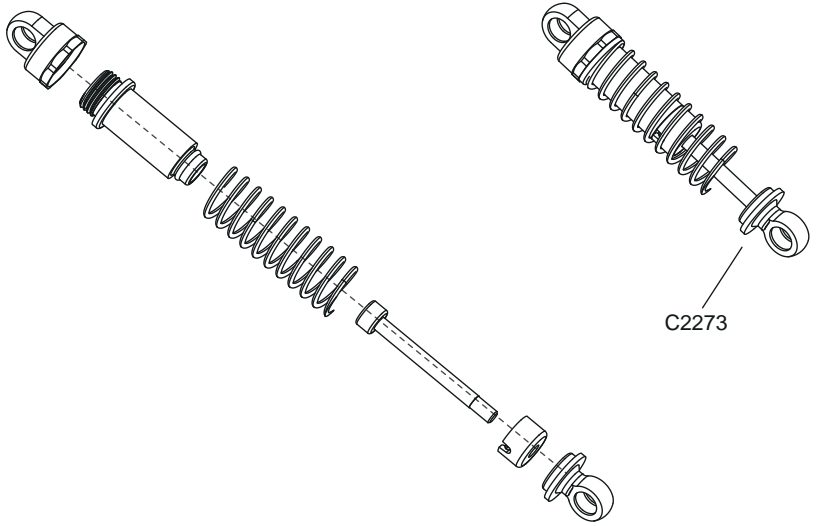

EN:WHEELS

CN:车轮

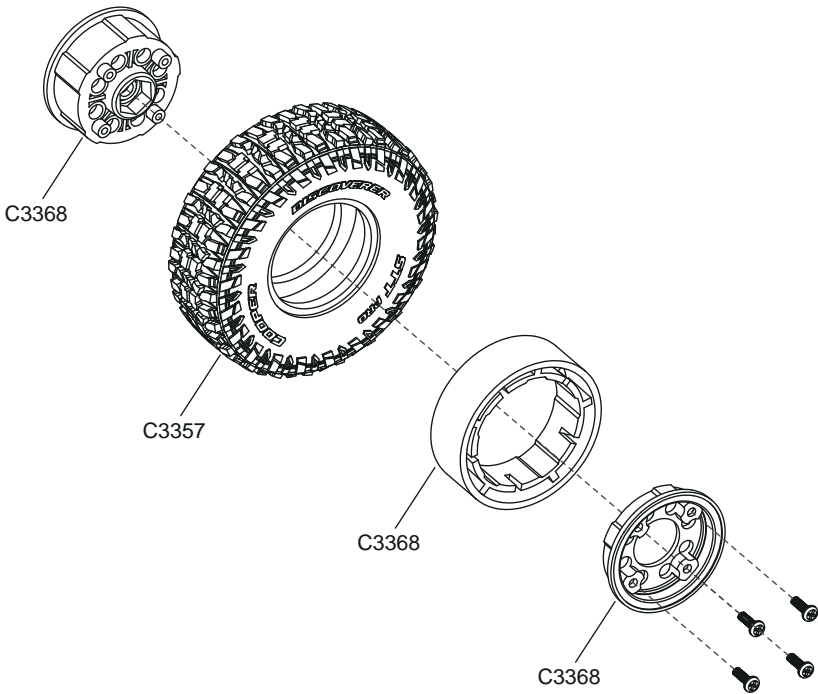

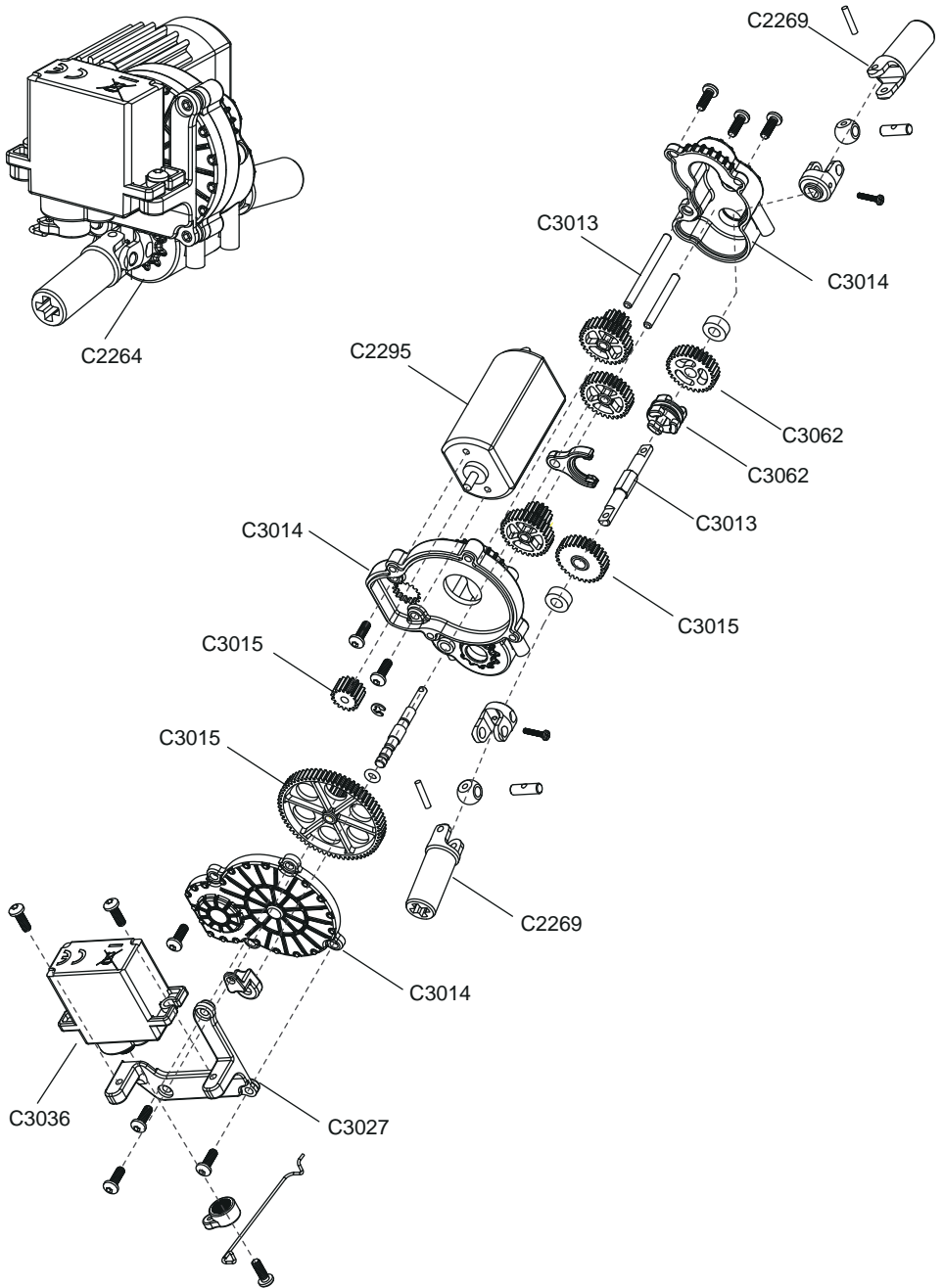

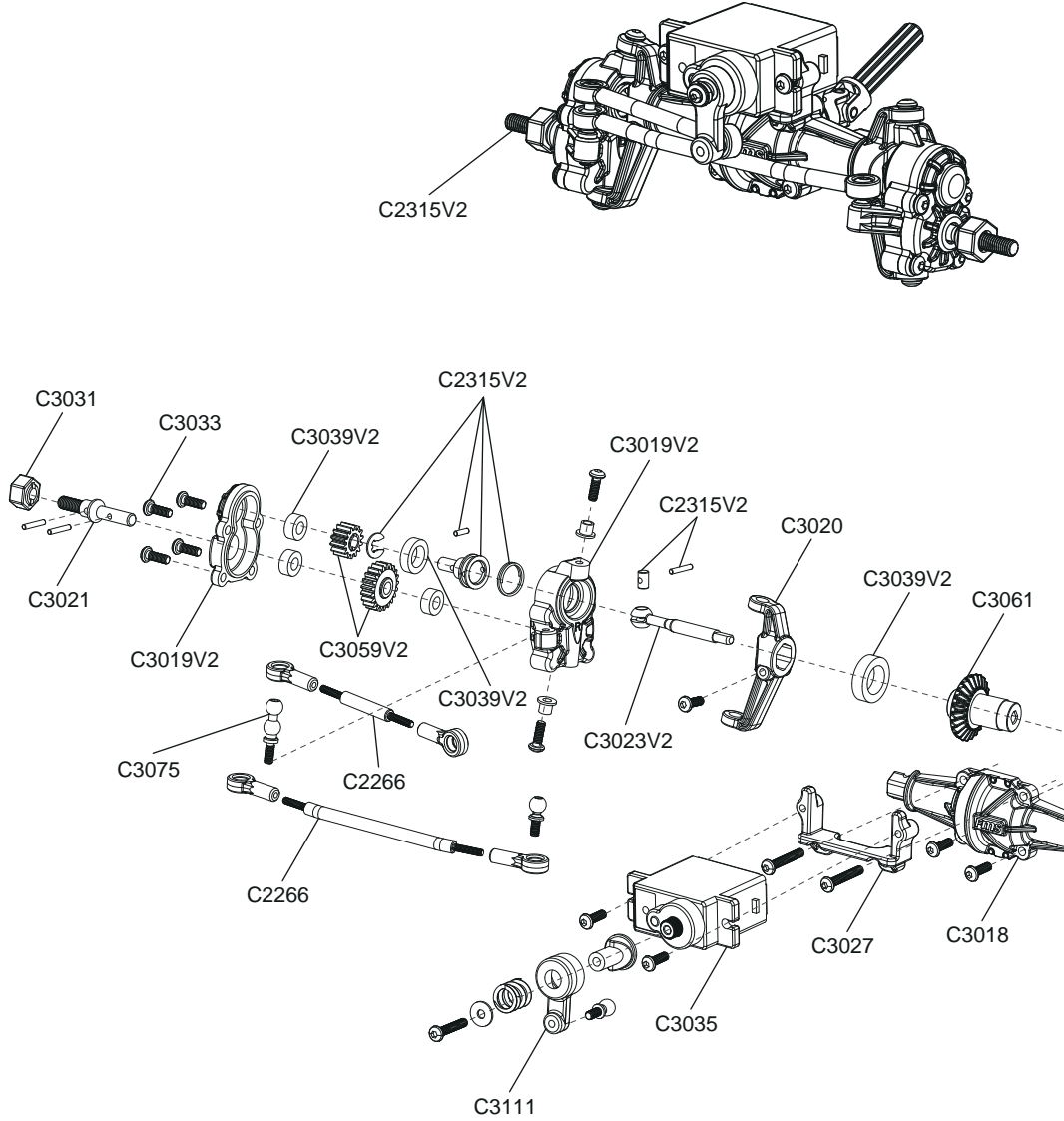

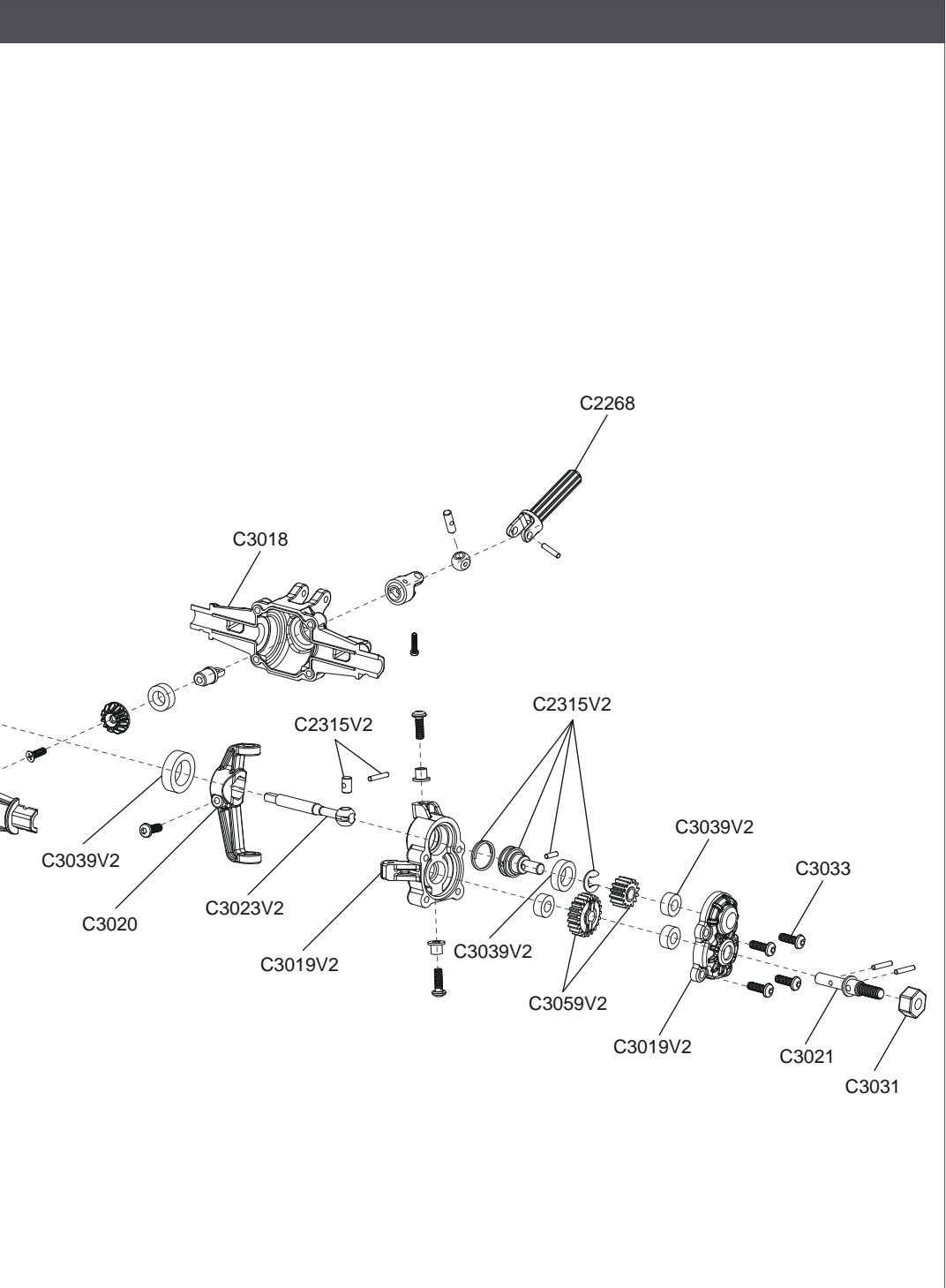

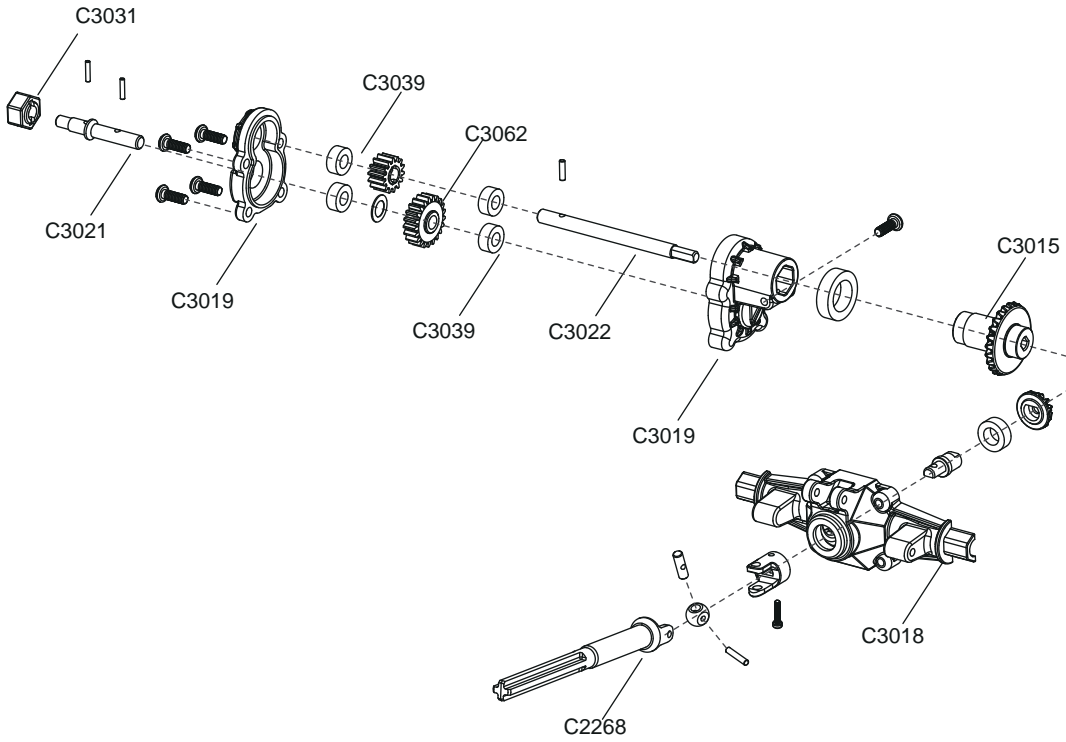

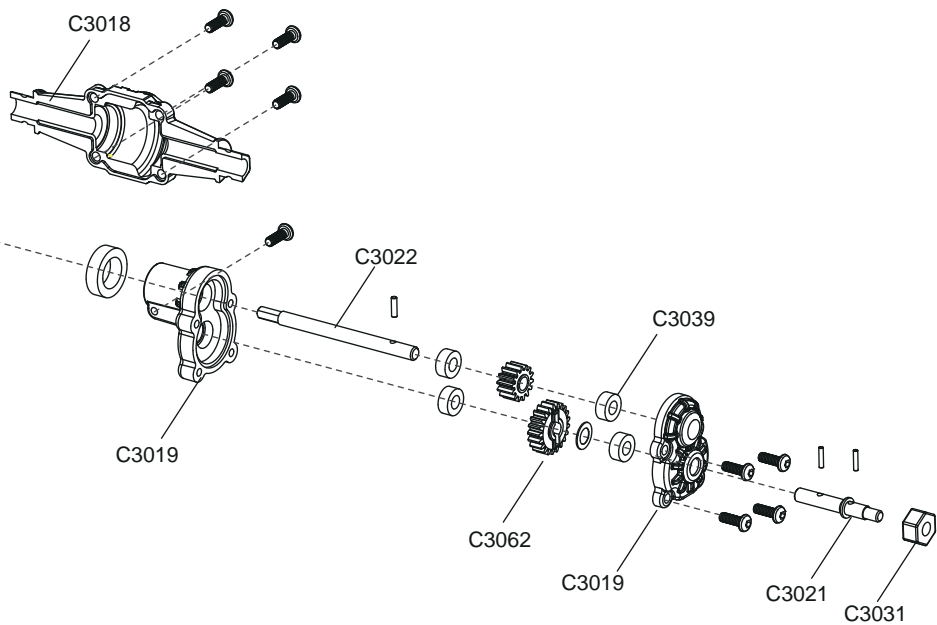
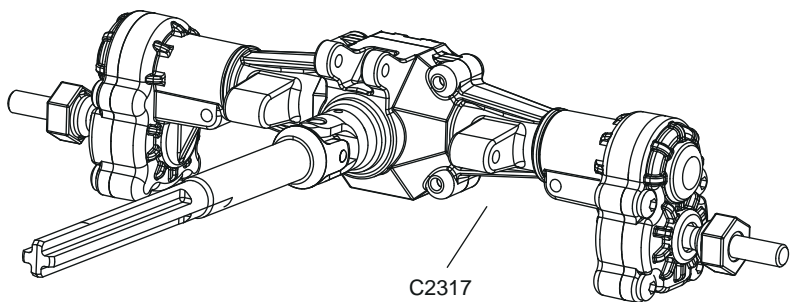

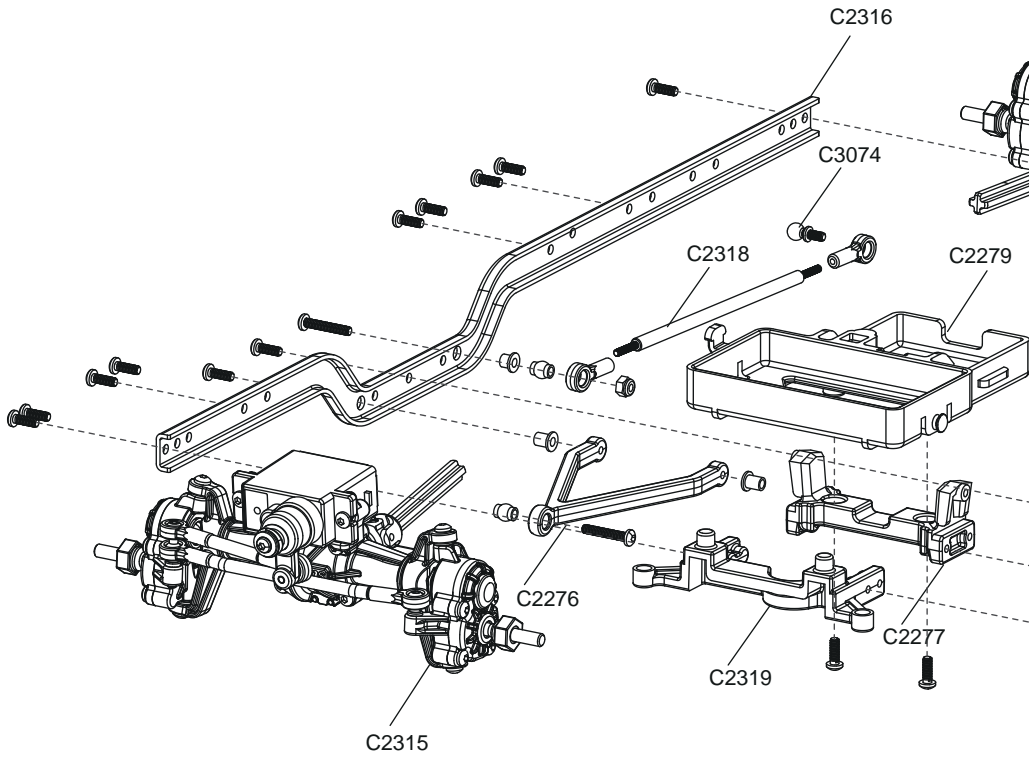

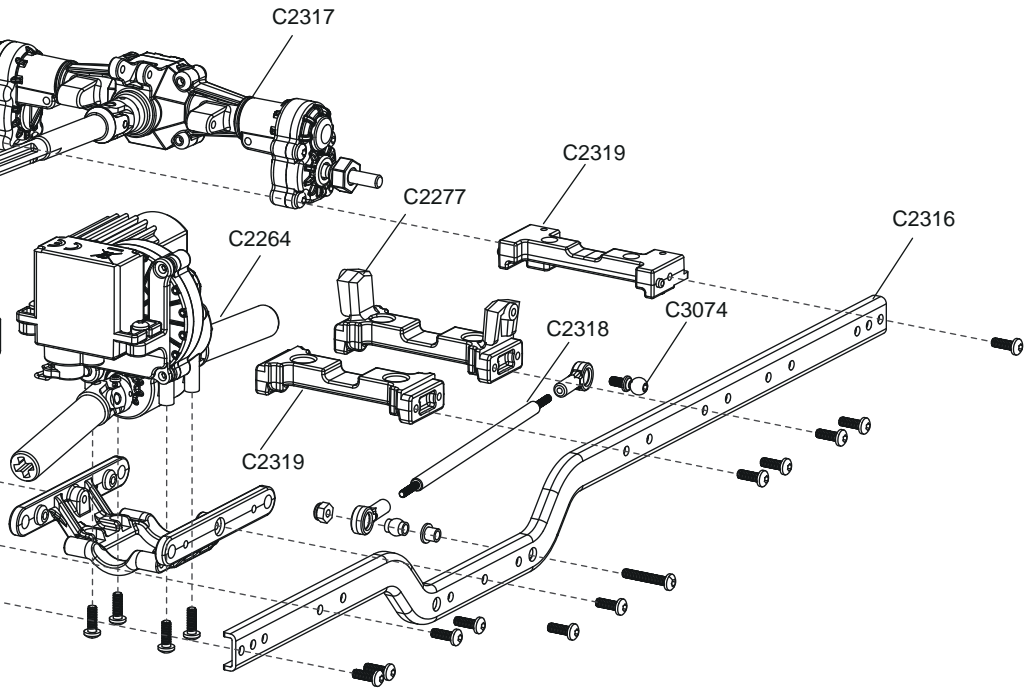

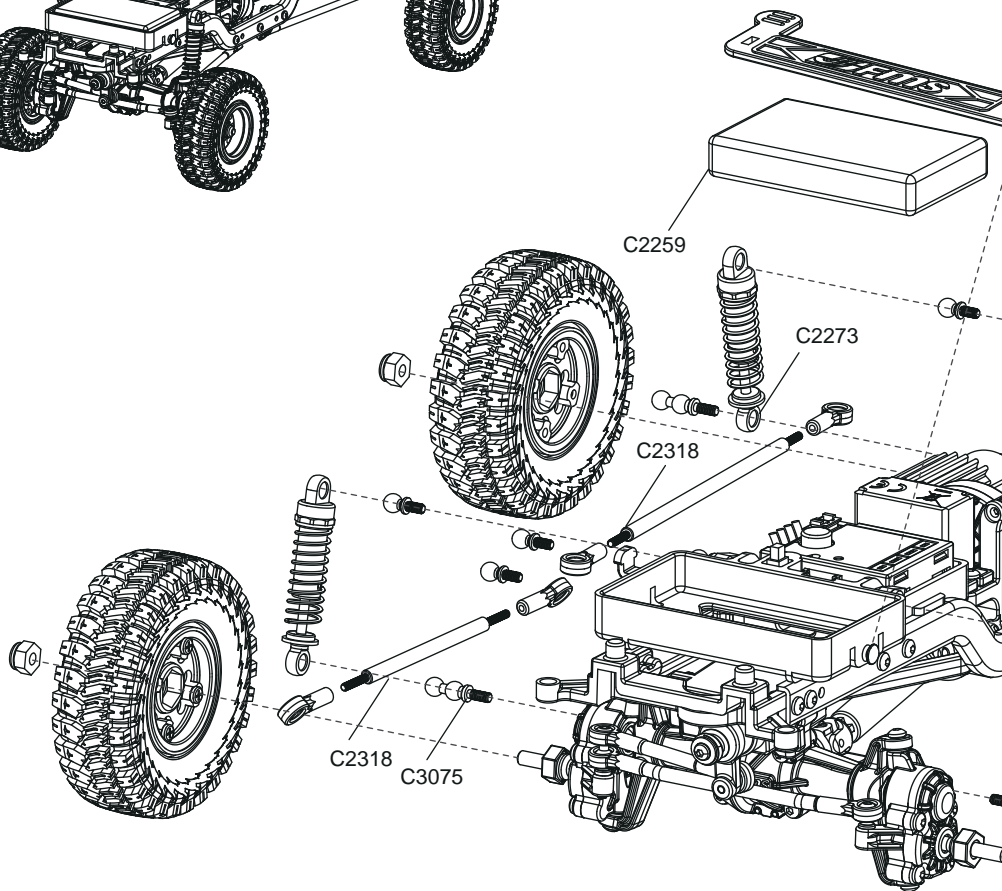
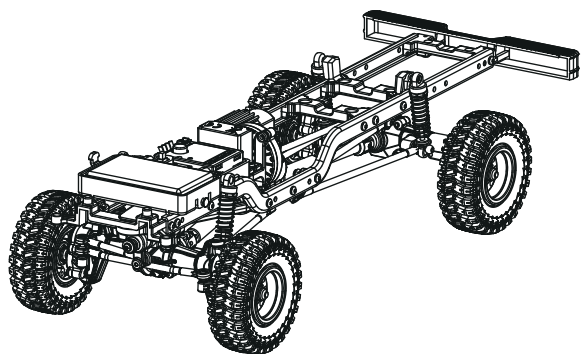

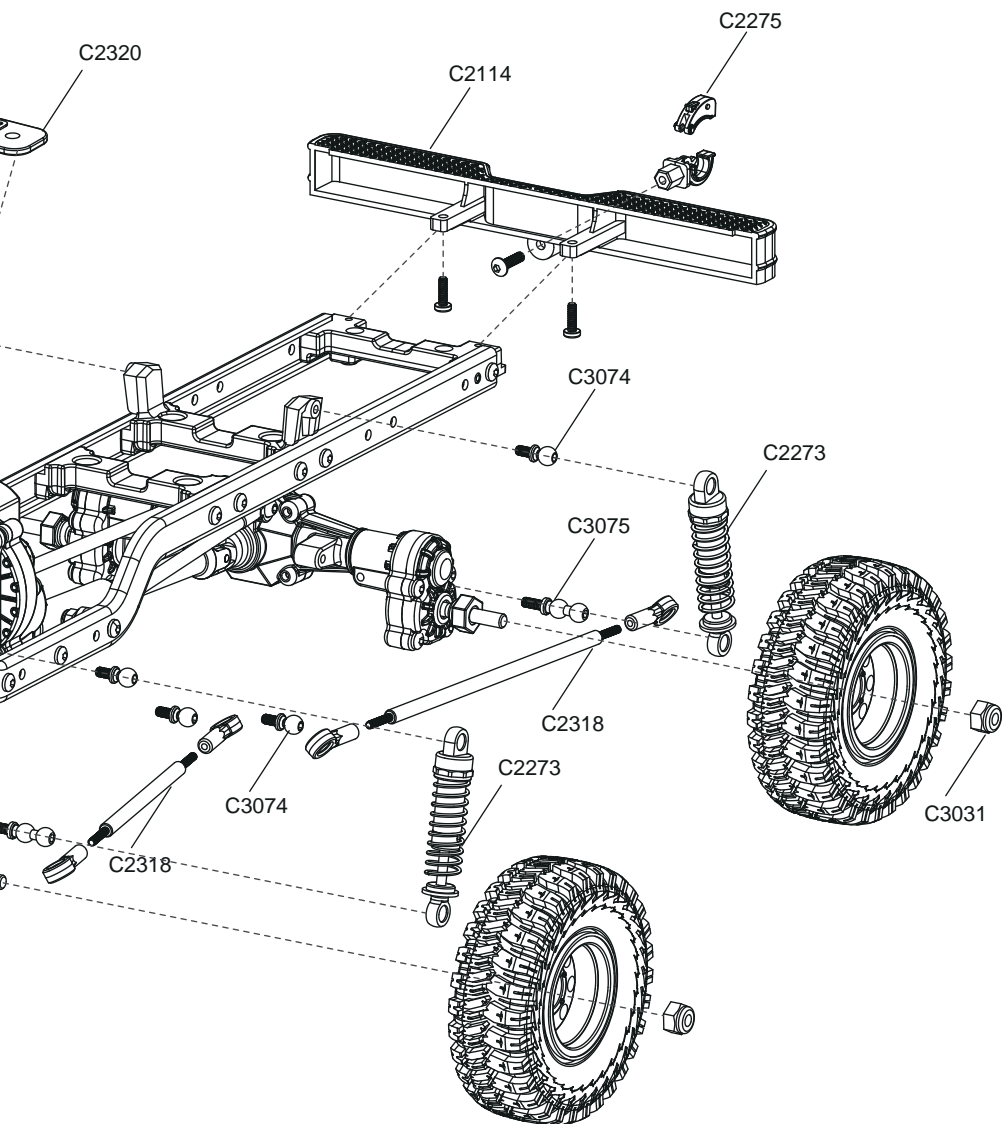

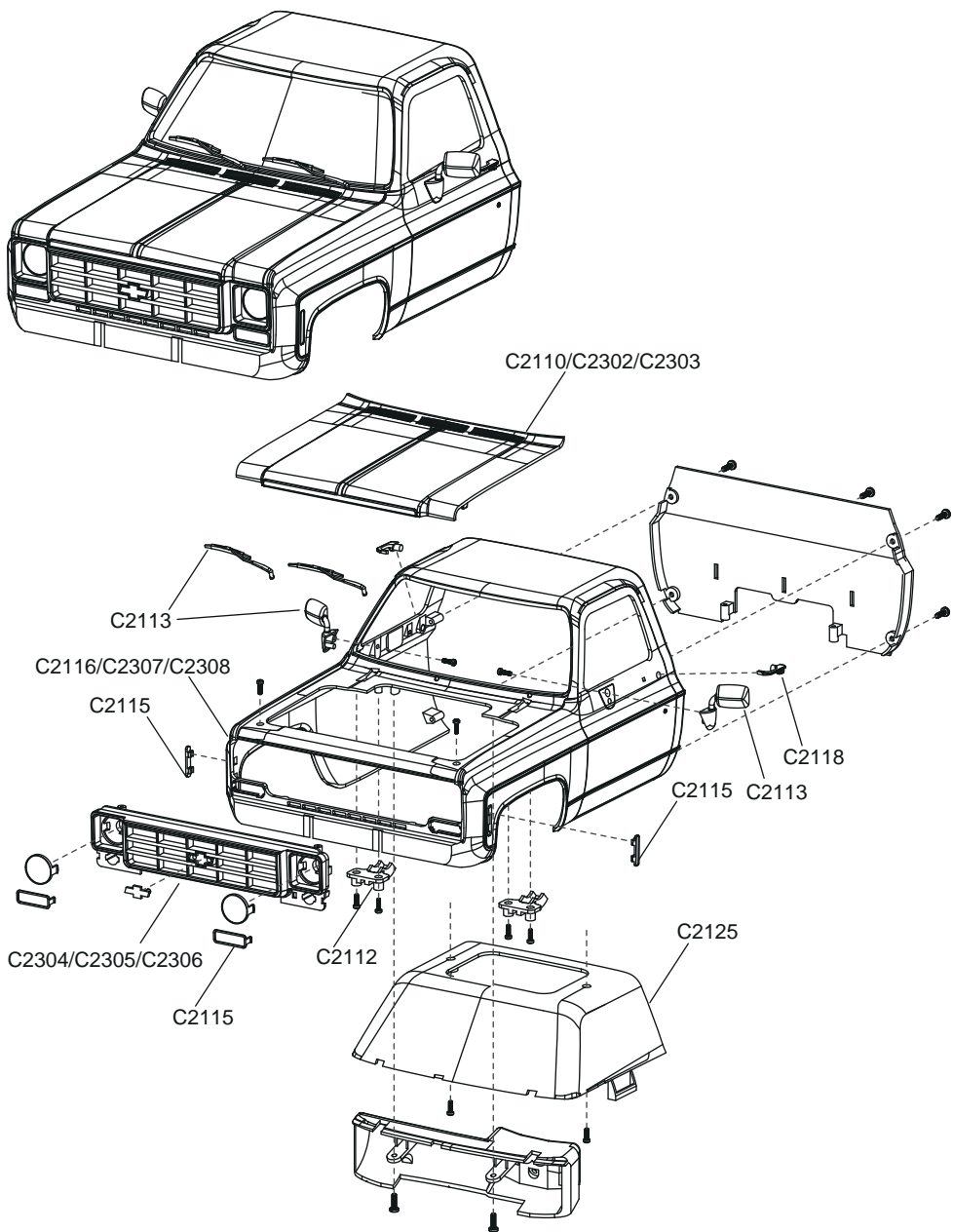

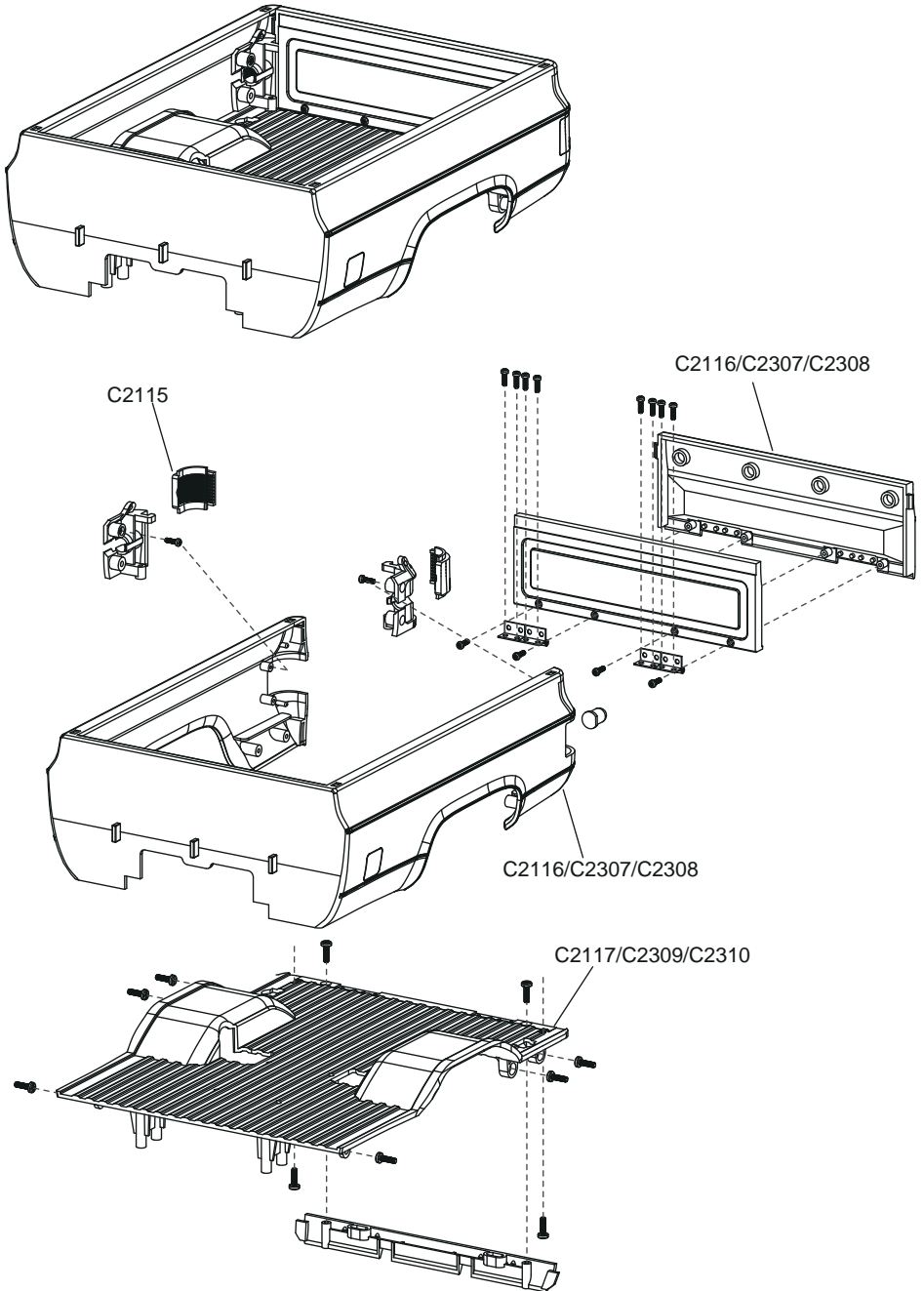

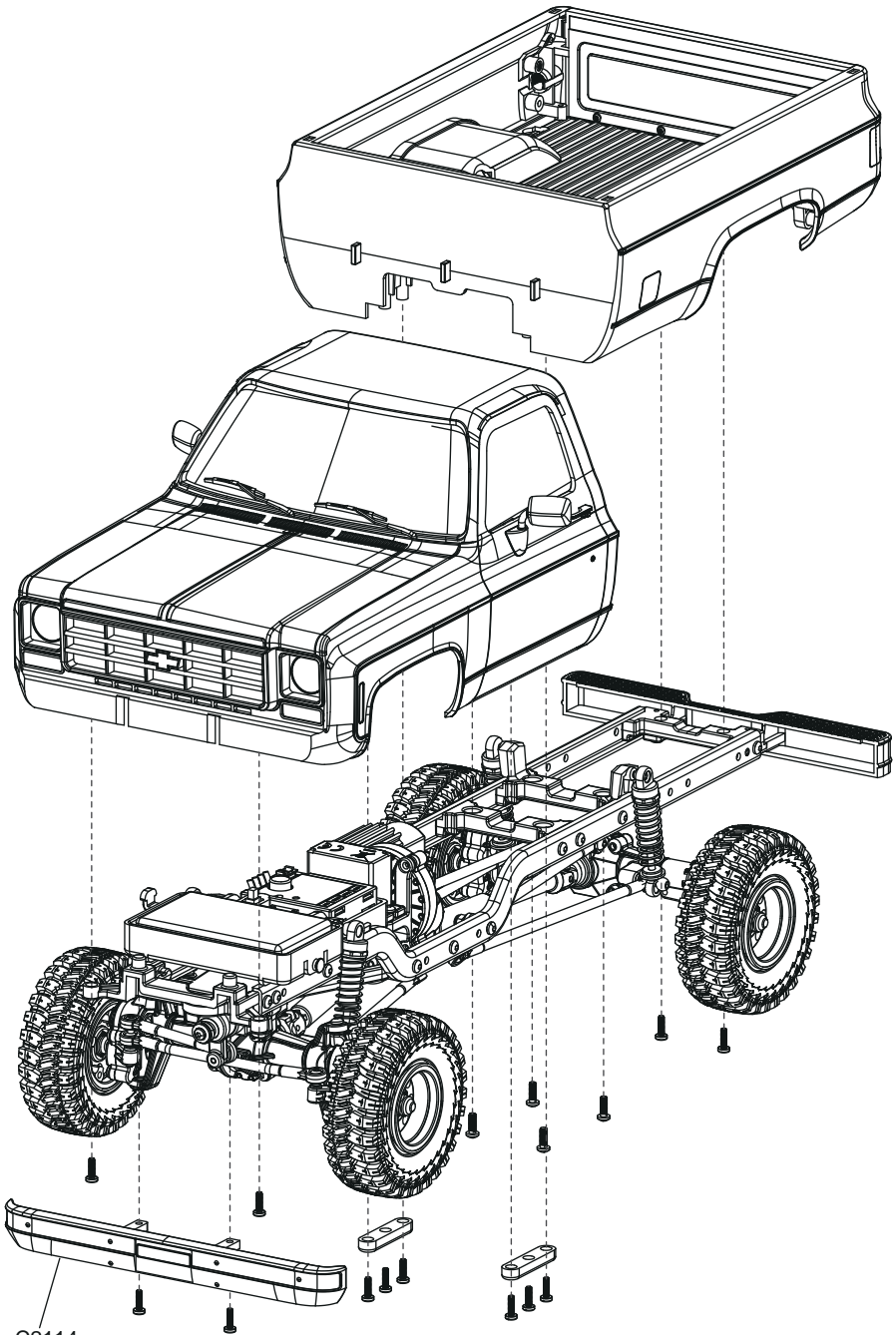

C2114



