

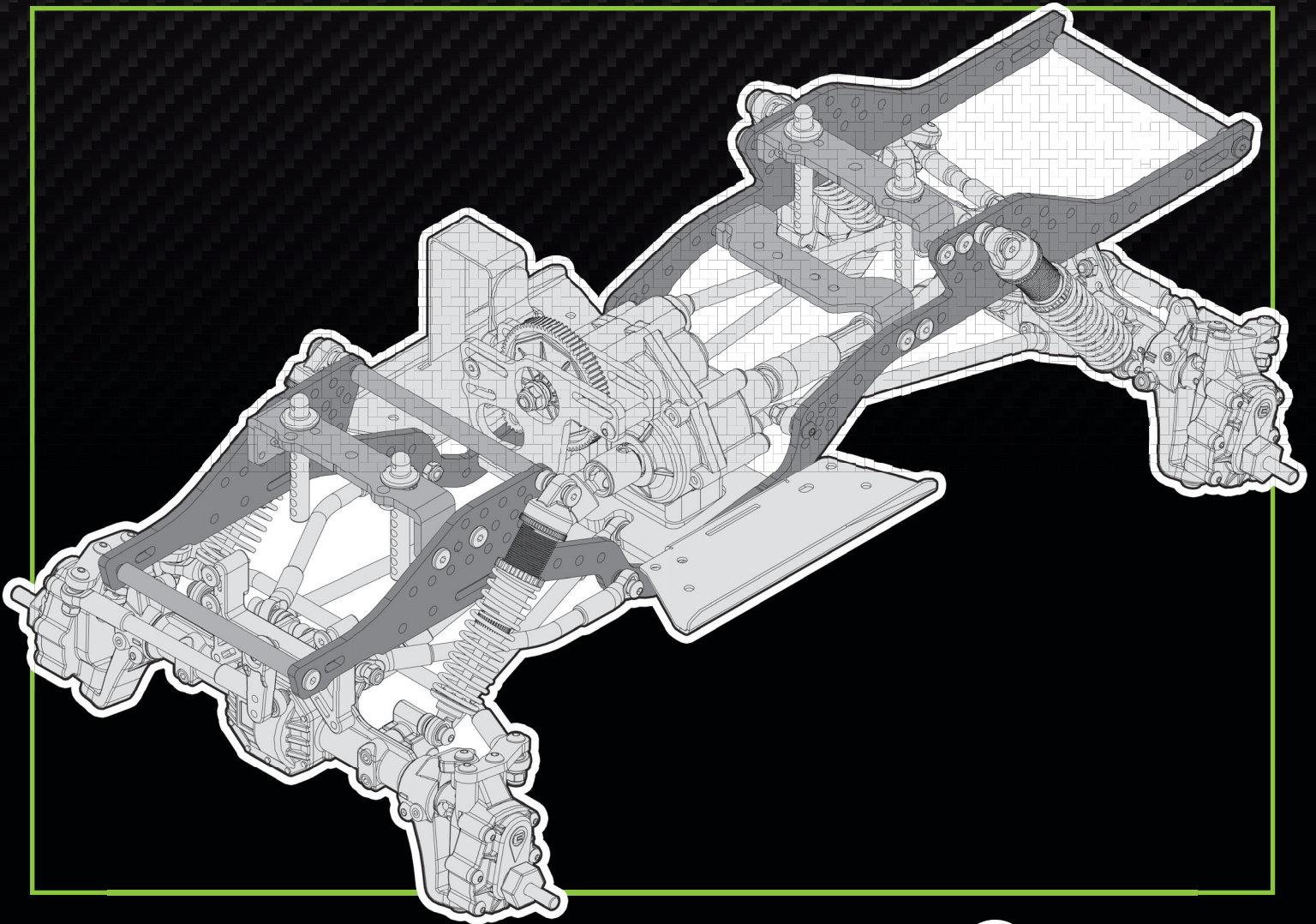

ENDURO **COMP FOX** COMPETITION ROCK CRAWLER KIT



OWNERS BUILD MANUAL





Associated Electrics, Inc.
21062 Bake Parkway.
Lake Forest, CA 92630

Customer Service
Tel: 949.544.7500
Fax: 949.544.7501

Follow Us On Social Media



ElementRC



@Element_RC

www.ElementRC.com

AE is a Registered Trademark of Associated Electrics, Inc.

TEAM ASSOCIATED is a Registered Trademark of Associated Electrics, Inc.

REEDY is a Registered Trademark of Associated Electrics, Inc.

FACTORY TEAM is a Registered Trademark of Associated Electrics, Inc.

ELEMENT™ is a Trademark of Associated Electrics, Inc.

AREA 51 is a Registered Trademark of Associated Electrics, Inc.

STEALTH is a Registered Trademark of Associated Electrics, Inc.

GREEN SLIME is a Registered Trademark of Associated Electrics, Inc.

ITEMS NEEDED

The following items are required to build or maintain your Enduro vehicle.

- 1.5mm Allen Wrench (#1500)
- 2mm Allen Wrench (#1501)
- 2.5mm Allen Wrench (#1503)
- Pliers
- Long Nose Pliers
- 5.5mm Nut Driver (#1507)
- 7mm Nut Driver (#1508)

OTHER HELPFUL ITEMS

The following items aren't required, but will aid in the building and maintaining of your Enduro vehicle.

- Threadlock (#1596) *Not Included
- Green Slime (#1105) *Not Included
- Black Grease (#6588)

Your journey begins here.



INTRODUCTION

Thank you for purchasing this Element RC product. This assembly manual contains instructions and tips for building and maintaining your new Enduro chassis. Please take a moment to read through this manual to help familiarize yourself with these steps. We are continually changing and improving our designs; therefore, actual parts may appear slightly different than in the illustrations. New parts will be noted on supplementary sheets located in the appropriate parts bags.

FEATURES

ENDURO, COMP FOX KIT CHASSIS FEATURES:

- **STEALTHR X TRANSMISSION:** Our transmission features the ability to adjust the rear drive ratio. In the box you get the standard 5.7% and 11.83% gear options. Paired with our all-new portal axles with zero percent underdrive, this is the perfect mild setup for the average crawler. If even more underdrive in the rear is desired, an optional 12/23 tooth gear set (#42372) is available separately for an additional 36% overdrive from axle-to-axle alone!

SERVO-ON-AXLE STEERING: Servo-on-axle steering provides better performance while keeping the vehicle's center of gravity low.

CARBON FIBER FLAT RAIL CHASSIS: The routed carbon fiber flat rail chassis, together with the aluminum chassis braces, is lightweight, rigid, strong, and provides plenty of suspension tuning options.

FACTORY TEAM SHOCKS: For ultra-smooth performance and looks, our machined aluminum threaded bronze-anodized shocks with black plastic caps and collars are included.

STEEL PIVOT BALLS: Steel pivot balls are strong, reliable, resistant to abrasion and friction wear while allowing the suspension to articulate smoothly even under extreme conditions.

DELRIN® ANGLED SKID: Machined from a solid low-friction Delrin® block, the lower skid plate is angled 7 degrees while keeping the transmission flat for more rear ground clearance and better breakover transitions.

FORWARD BIAS MOTOR MOUNT: The two-piece aluminum motor mount flips the motor forward and low for more frontend weight bias while keeping the center of gravity as low as possible.

PORTAL AXLES: When it comes to rock crawling, ground clearance is crucial. That's why the Enduro Comp Fox competition rock crawler kit includes our all-new high-clearance portal axles. With almost an inch of added center axle clearance over standard straight axles, getting over tough obstacles is a breeze. To battle the massive amount of torque inherent with portal axles, we not only utilized metal gears throughout, but also use six screws to hold the portal gear boxes tight. That many screws ensures a stronger portal box and less chance of gears pulling apart under heavy loads.









ADDITIONAL FEATURES:

- NEW high-clearance portal axles
- NEW carbon fiber flat rail chassis
- NEW aluminum chassis braces and body mount supports
- NEW Delrin® machined and flush mounted angled lower skid plate
- NEW 2-piece forward-bias aluminum motor plate
- Factory Team aluminum threaded shocks
- Factory Team steel pivot balls
- Factory Team 5mm heavy-duty steel high-clearance links
- Servo-on-axle steering
- Universal front drive axles
- Aluminum steering plates
- Optimized ball cups for more fluid axle articulation
- Telescopic driveshafts front and rear
- Extruded aluminum driveshaft splines
- Machined input pinion gear
- Metal ring gear
- Machined steel top shaft
- Metal ball bearings included
- Steel 25T servo horn

















HARDWARE 1:1 SCALE VIEW

HARDWARE USED WITH OPTIONAL REPLACEMENT PART NUMBERS









FLAT HEAD SCREWS (FHCS)

| | |
|----------------------------------------------------------------------------------|------------------|
|  | 2.5x10mm (31350) |
|  | 2.5x14mm (41077) |
|  | 3x6mm (31541) |
|  | 3x8mm (25201) |
|  | 3x10mm (25202) |
|  | 3x12mm (25203) |
|  | 3x14mm (89208) |
|  | 3x20mm (89210) |
|  | 3x24mm (89233) |





BUTTON HEAD SCREWS (BHCS)

| | |
|------------------------------------------------------------------------------------|--------------------------------|
|  | 2x3mm (31509) |
|  | 2.6x10mm, Self Tapping (41088) |
|  | 3x4mm (91158) |
|  | 3x5mm (31530) |
|  | 3x6mm (31531) |
|  | 3x8mm (31532) |
|  | 3x10mm (25211) |
|  | 3x12mm (89202) |
|  | 3x14mm (25187) |
|  | 3x16mm (89203) |
|  | 3x18mm (2308) |
|  | 3x20mm (25188) |
|  | 3x22mm (25189) |
|  | 3x24mm (89204) |
|  | 3x26mm (89205) |
|  | 3x28mm (41078) |
|  | 3x45mm (71037) |





SOCKET HEAD SCREWS (SHCS)

| | |
|-----------------------------------------------------------------------------------|------------------|
|  | 2x5mm (31511) |
|  | 2x8mm (7187) |
|  | 2.5x6mm (41079) |
|  | 2.5x10mm (41087) |
|  | 2.5x14mm (71032) |
|  | 2.5x16mm (41086) |
|  | 2.6x10mm (42332) |
|  | 3x6mm (41089) |



LP SOCKET HEAD SCREWS (LP SHCS)

| | |
|------------------------------------------------------------------------------------|----------------|
|  | 3x6mm (41089) |
|  | 3x10mm (41090) |
|  | 3x16mm (41092) |
|  | 3x20mm (41091) |



SET SCREWS

| | |
|-------------------------------------------------------------------------------------|---------------|
|  | 3x3mm (25225) |
|  | 3x6mm (81257) |
|  | 3x16mm (4689) |
|  | 4x16mm (4677) |





PIVOT BALLS

| | |
|-------------------------------------------------------------------------------------|-----------------------------------------------------------------------|
|  | Pivot Ball, 6mm (42041) FT Pivot Ball, 6mm (42056) |
|  | Pivot Ball, Upper Shock (42041) FT Pivot Ball, Upper Shock (42055) |







LOCK NUTS

| | |
|-------------------------------------------------------------------------------------|-----------------------------------------|
|  | M3 Locknuts (25215) Aluminum (31550) |
|  | M4 Locknut W/Flange (25391) |

BEARINGS

| | |
|-------------------------------------------------------------------------------------|--------------------|
|  | 5x10x4mm (91560) |
|  | 5x12x4mm (91567) |
|  | 7x14x3.5mm (91474) |
|  | 10x15x4mm (91563) |

SHIMS AND WASHERS

| | |
|---------------------------------------------------------------------------------------|-------------------------|
|  | 3x7mmx1mm (42260) |
|  | 3x7mmx2mm (42260) |
|  | 3x7x3mm (42260) |
|  | 3x7x5mm (42260) |
|  | 3x7x7mm (42260) |
|  | Drive Gear Shim (42027) |

MISC. SCREWS





| | |
|---------------------------------------------------------------------------------------|---------------------------------|
|  | Shoulder Screw 3x4x10mm (42070) |
|  | Screw Pin (42022) |
|  | Pin 2x9mm (31872) |
|  | Pin 2x11mm (42019) |

TABLE OF CONTENTS

2/10/2025

| | | | |
|-----------|-------------------------|-----------|------------------------|
| 01 | COVER | 09 | LINKS BUILD |
| 02 | INTRODUCTION | 12 | DRIVESHAFTS BUILD |
| 03 | 1:1 HARDWARE "FOLD OUT" | 13 | SHOCKS BUILD |
| 04 | TABLE OF CONTENTS | 15 | BODY MOUNTS BUILD |
| 05 | CHASSIS BUILD | 16 | OPTIONAL GEARBOX BUILD |
| 05 | TRANSMISSION BUILD | 17 | TRAIL TIPS |
| 06 | FRONT PORTAL AXLE BUILD | 18 | BACK COVER |
| 08 | REAR PORTAL AXLE BUILD | | |

USING THIS MANUAL



This symbol indicates a special note or instruction in the manual.

x2

This symbol indicates the number of the same part that is required.



This symbol indicates the order within a step to assemble parts.



This symbol indicates a Trail Tip.



This symbol indicates where Black Grease should be applied.



This symbol indicates where Green Slime can be applied.



This symbol indicates where Thread Lock Adhesive should be applied.



This symbol indicates where Shock Fluid should be applied.



There is a 1:1 hardware foldout page in the front of the manual. To check the size of a part, line up your hardware with the correct drawing until you find the exact size. Each part in the foldout has a number assigned to it for ordering replacement parts.

GATE 01 CHASSIS BUILD: BAG 1, 2



NOTE: Leave the screws slightly loose in order to install the skid plate/transmission build later on.

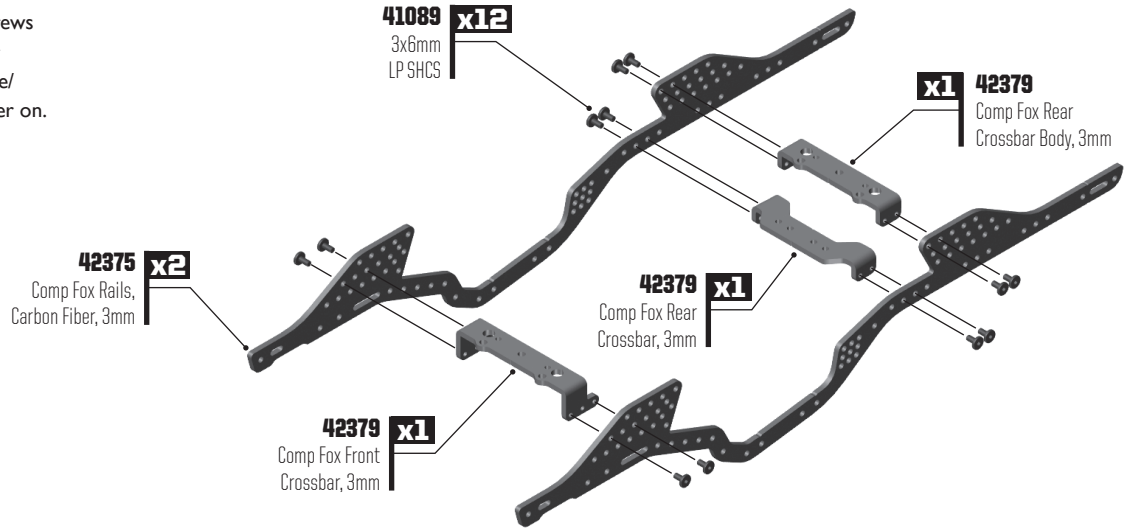

GATE 01 TRANSMISSION BUILD: BAG 3

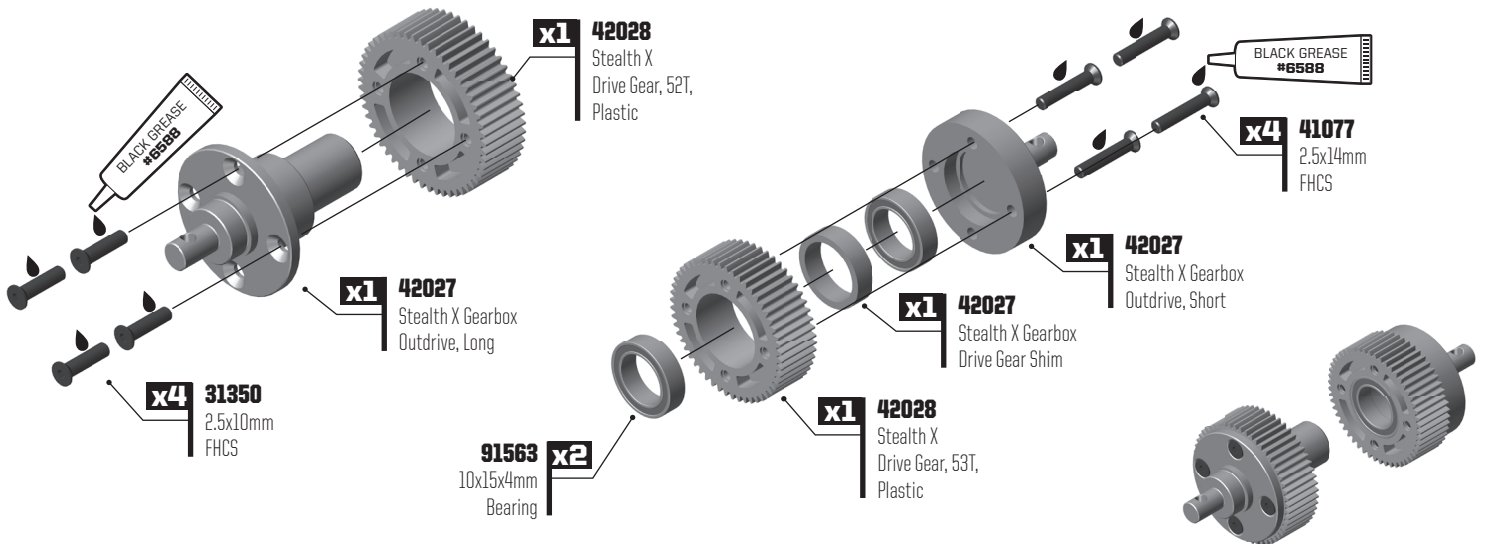

GATE 02 TRANSMISSION BUILD: BAG 3

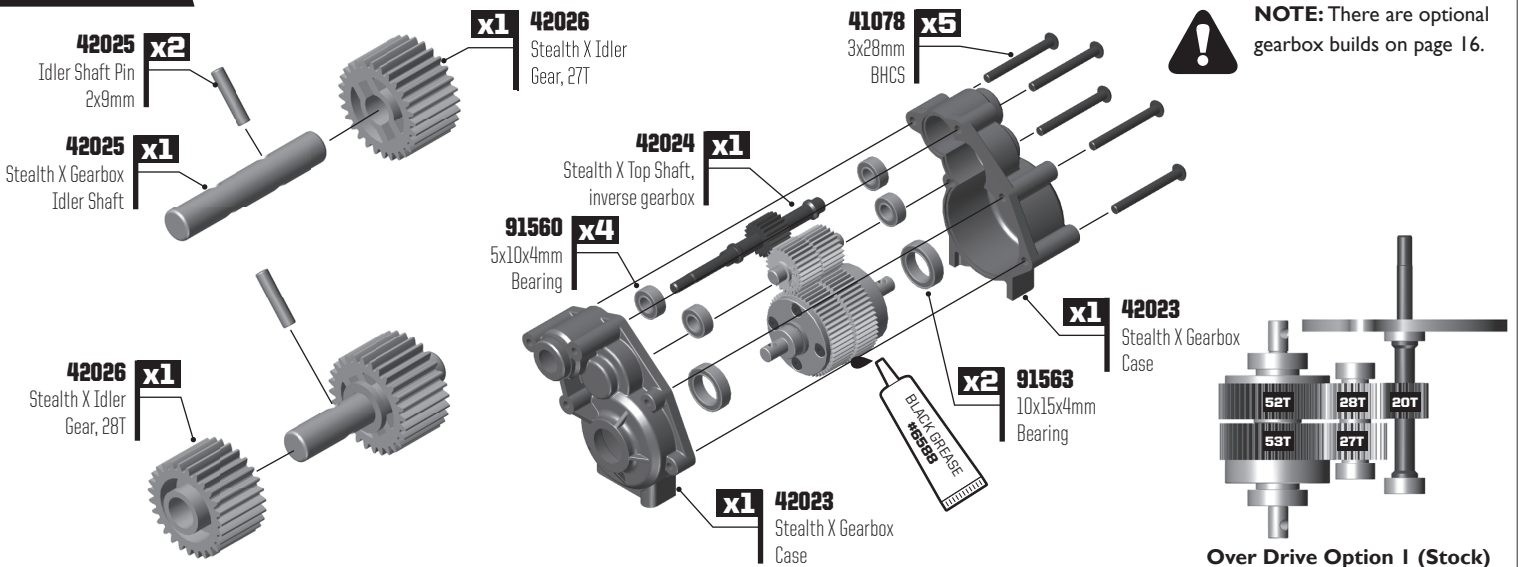

GATE 03 TRANSMISSION BUILD: BAG 3

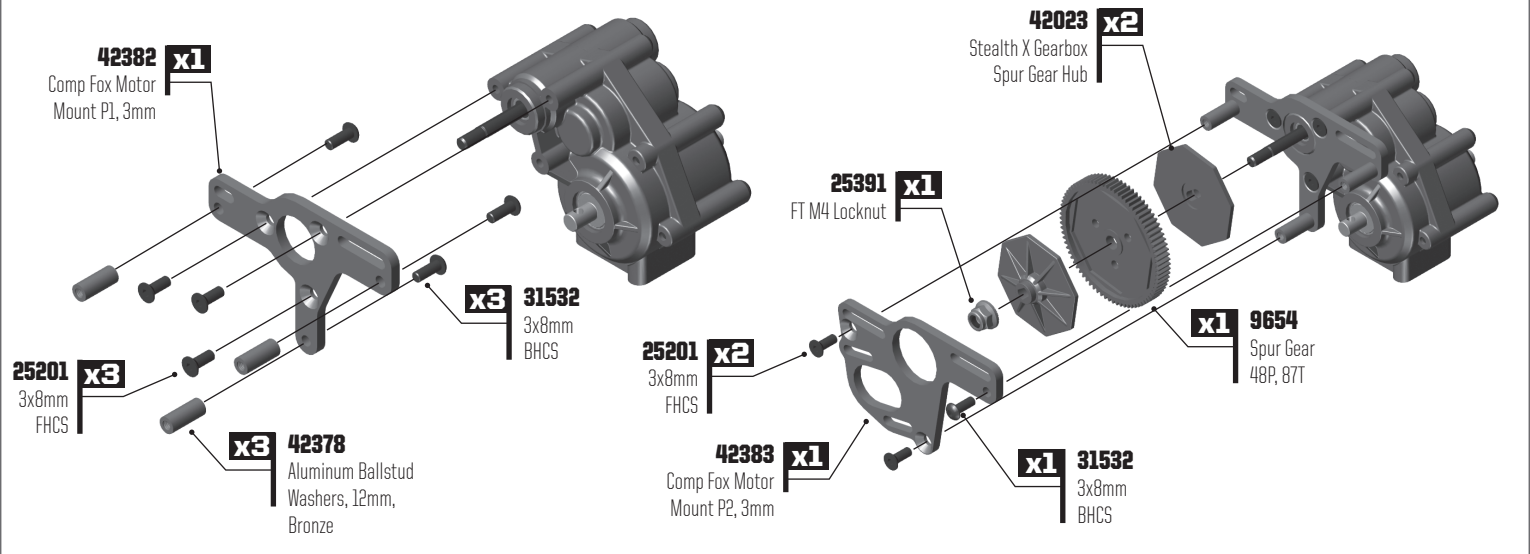

GATE 04 TRANSMISSION BUILD: BAG 3

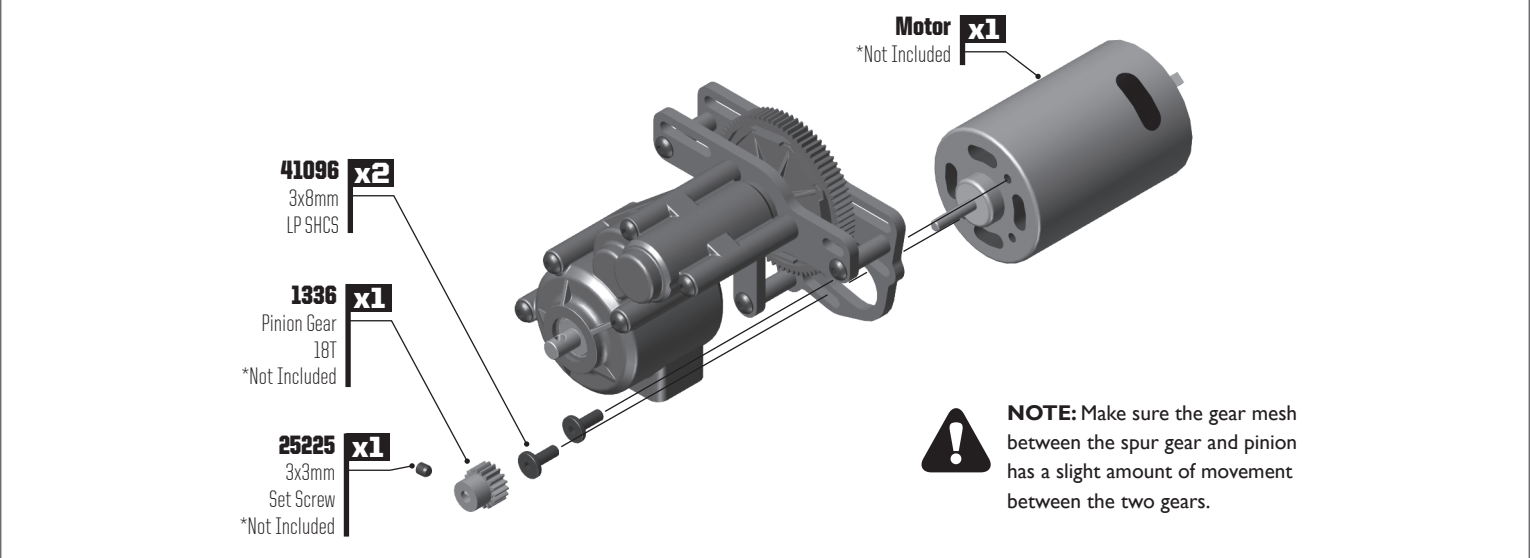

GATE 01 FRONT PORTAL AXLE BUILD: BAG 4

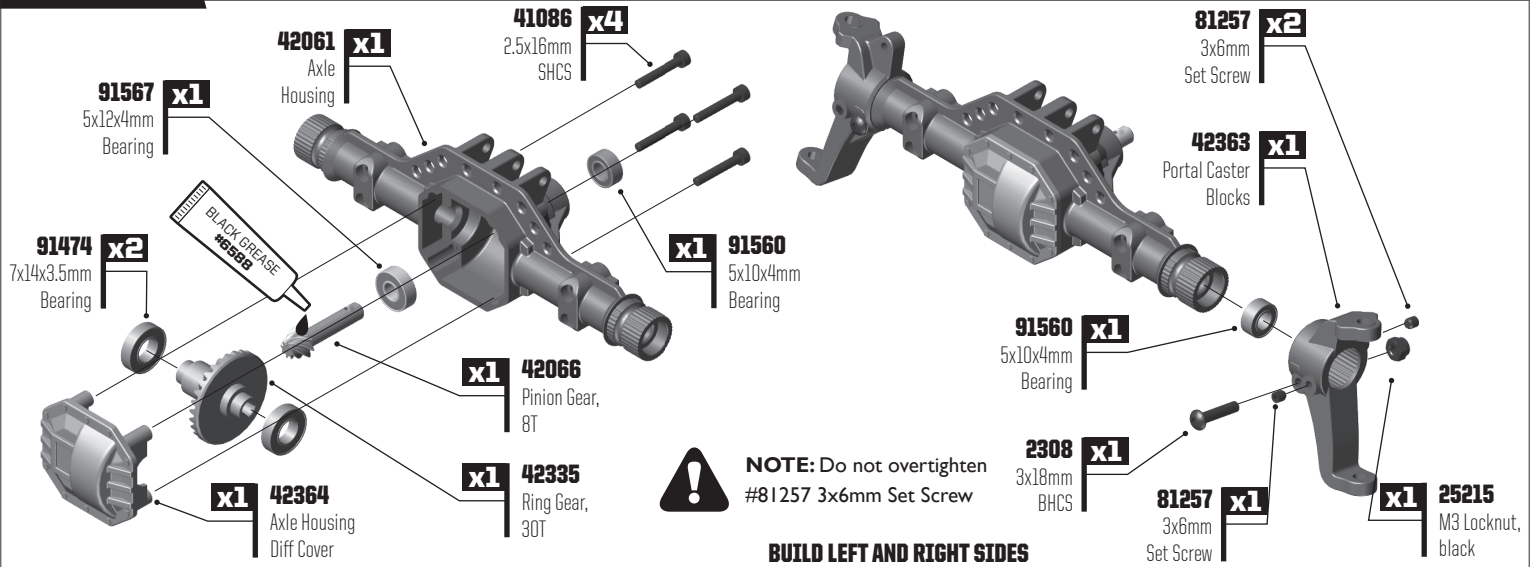

GATE 02 FRONT PORTAL AXLE BUILD: BAG 4

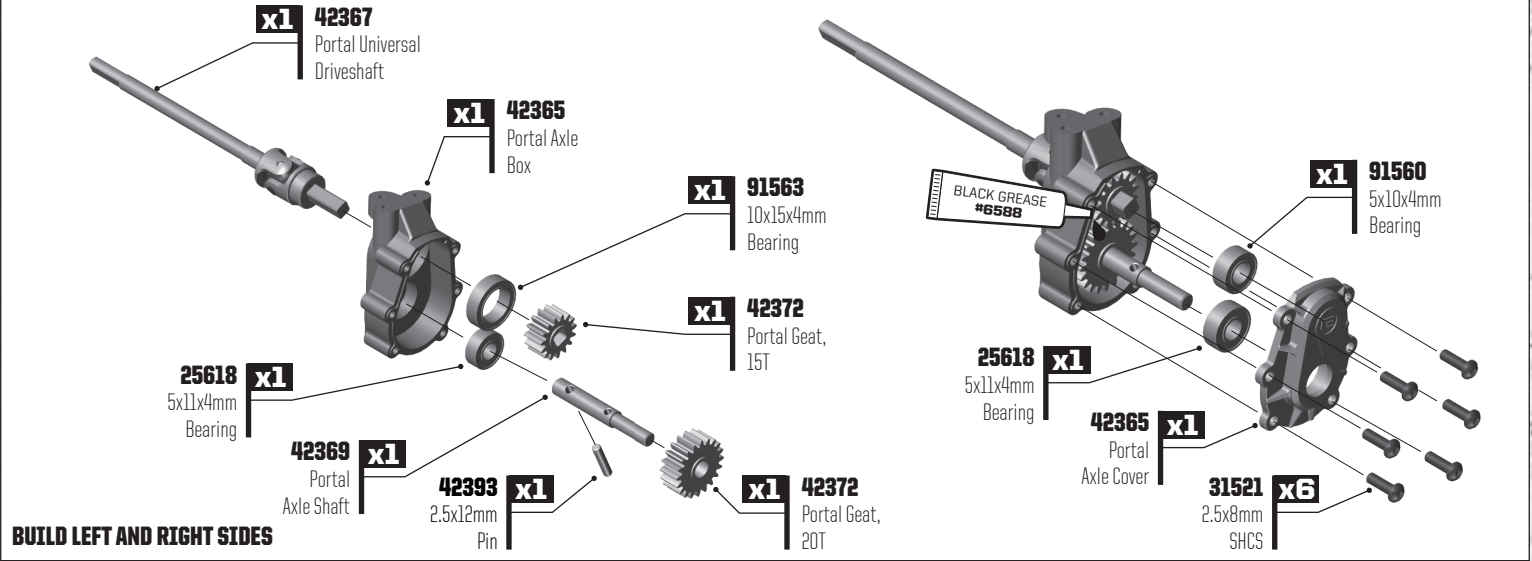

GATE 03 FRONT PORTAL AXLE BUILD: BAG 4

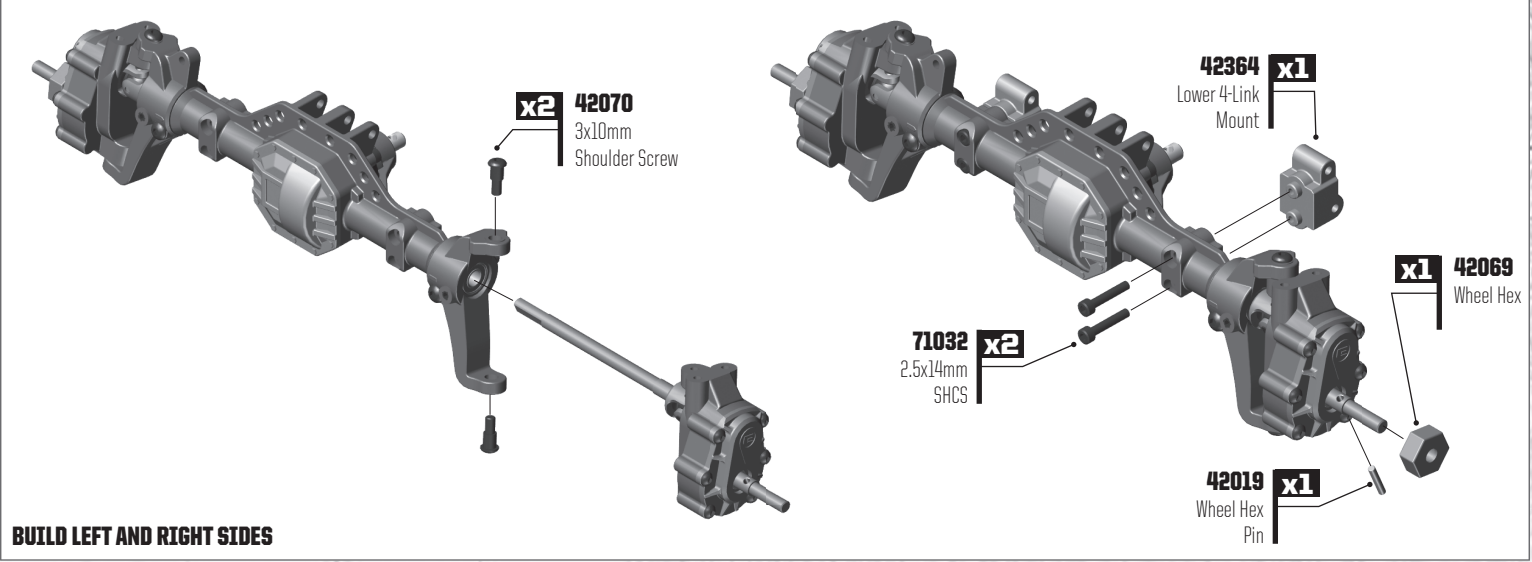

GATE 04 FRONT PORTAL AXLE BUILD: BAG 4

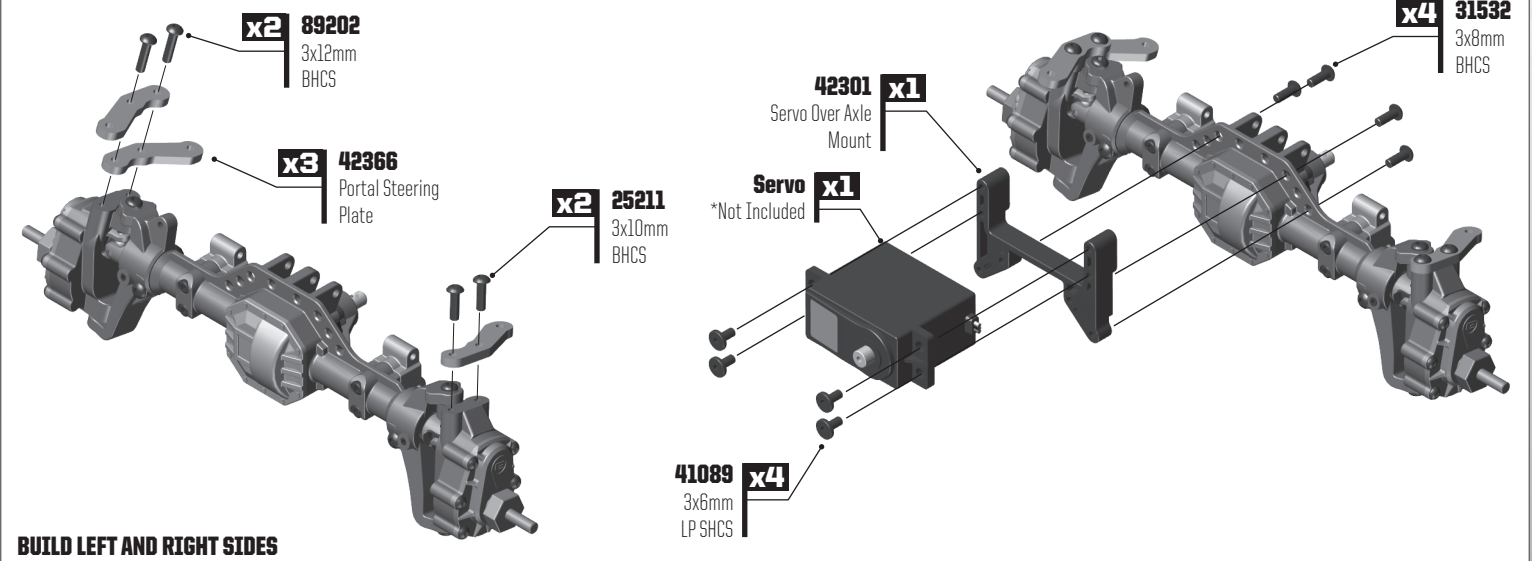

GATE 01

REAR PORTAL AXLE BUILD: BAG 5

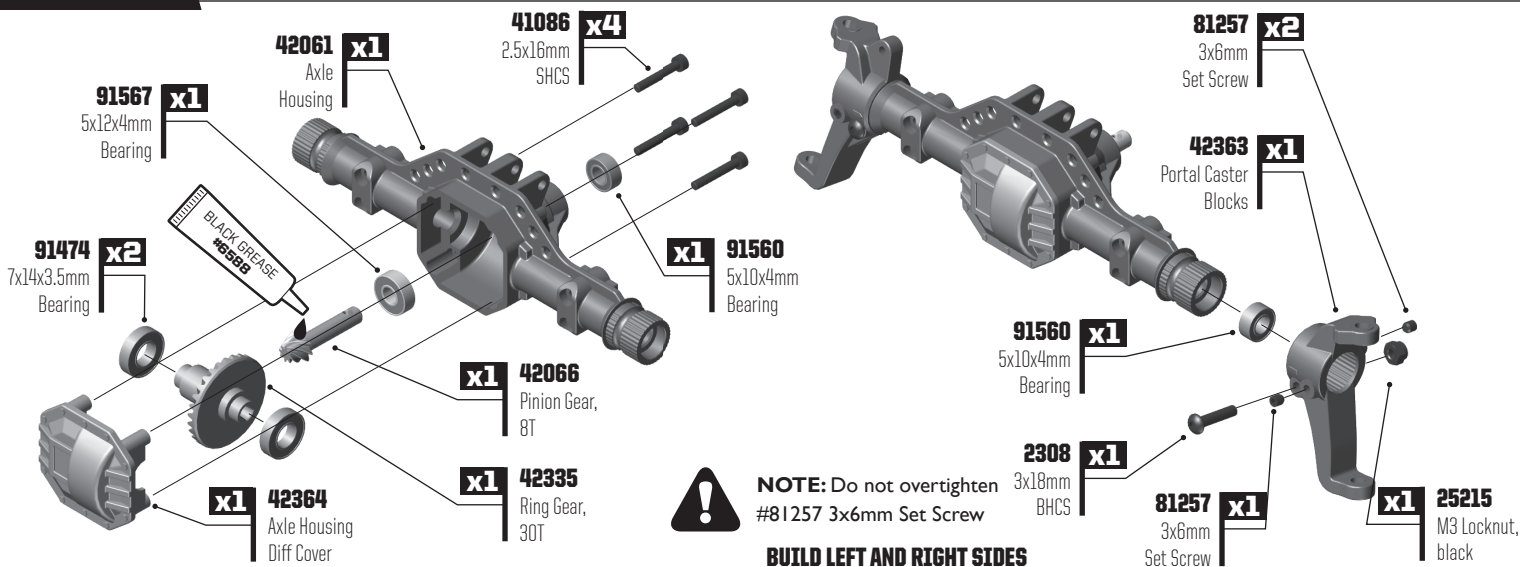

GATE 02

REAR PORTAL AXLE BUILD: BAG 5

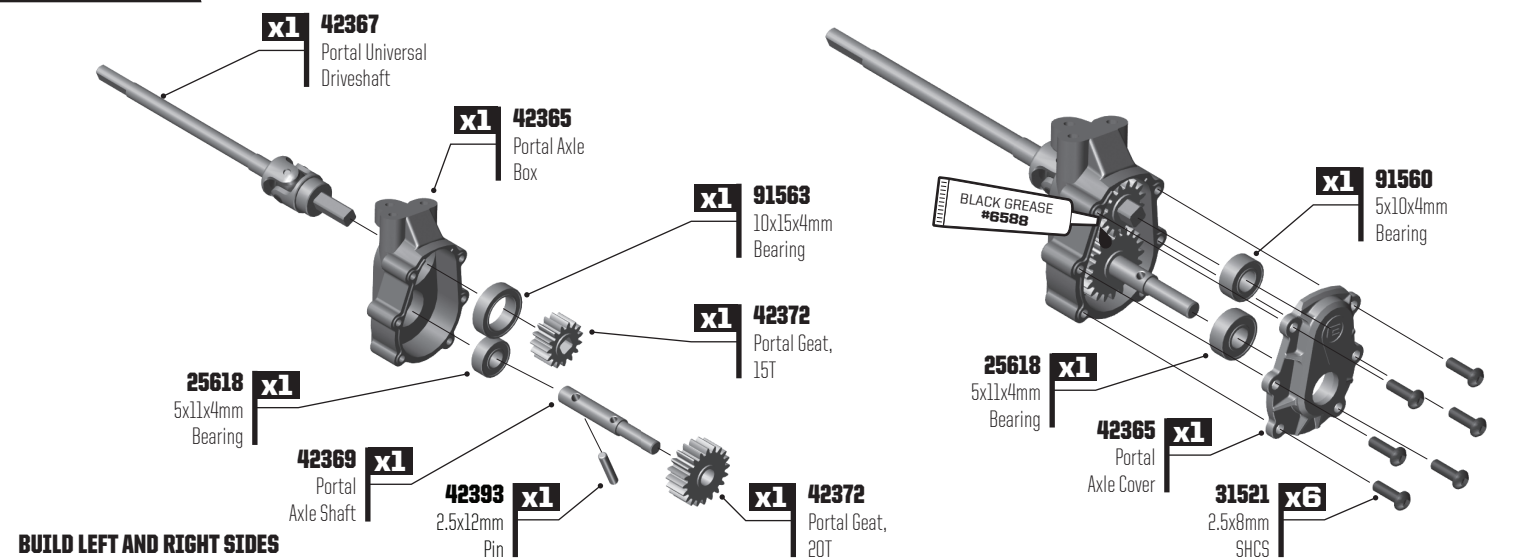

GATE 03

REAR PORTAL AXLE BUILD: BAG 5

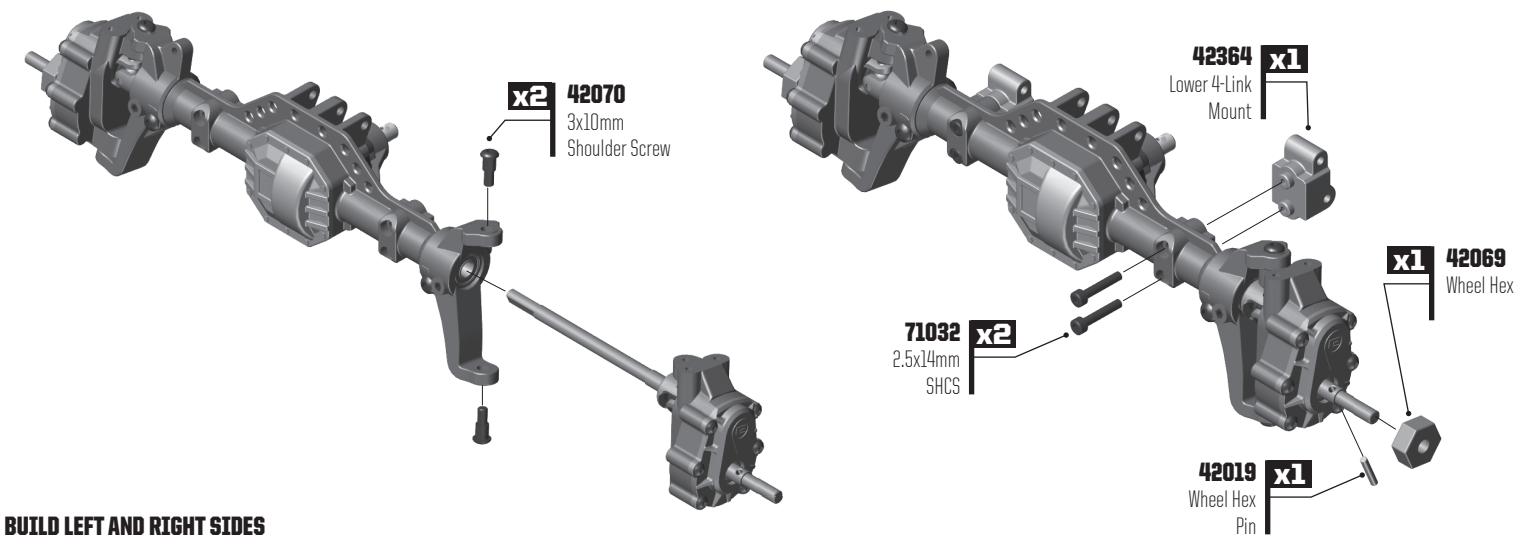

GATE 04 REAR PORTAL AXLE BUILD: BAG 5

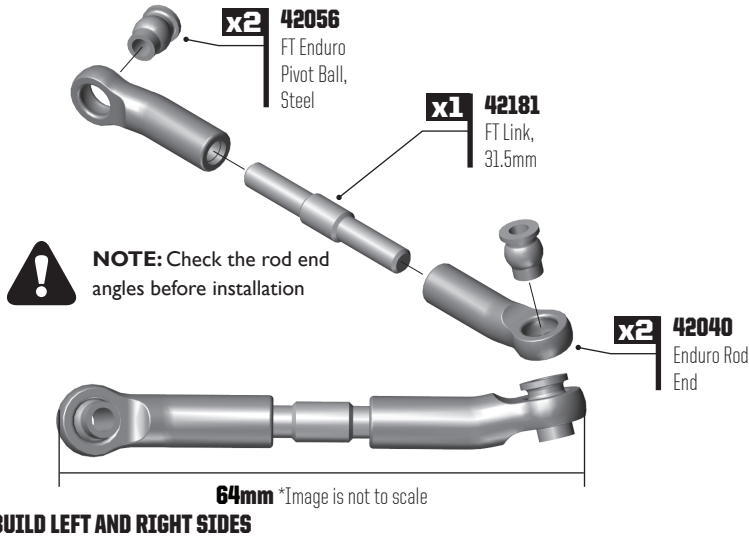

BUILD LEFT AND RIGHT SIDES

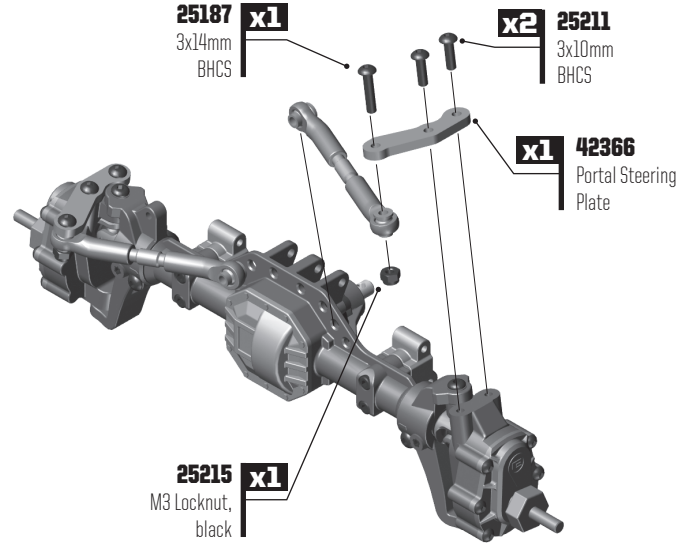

GATE 05 REAR PORTAL AXLE BUILD: BAG 5

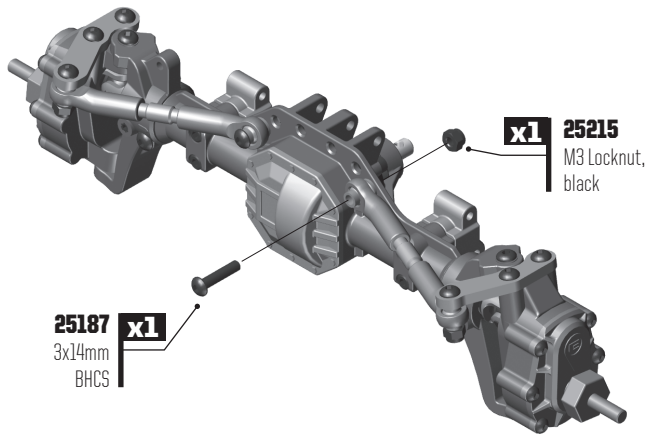

BUILD LEFT AND RIGHT SIDES

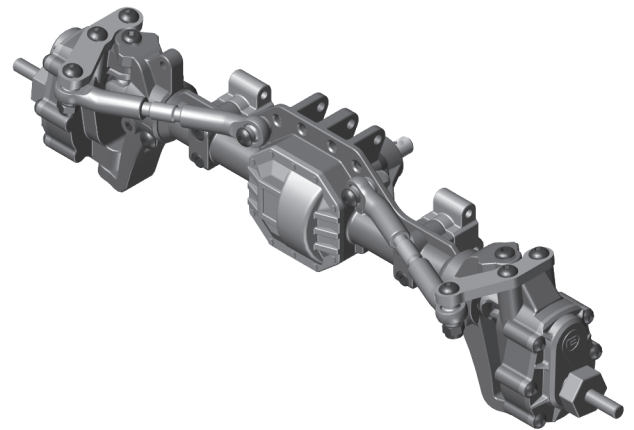

NOTE: Adding Portal Axles to your crawler will increase the torque and reduce your gear ratio. It is recommended to use a 78T spur gear with these Portal Axles in order to achieve the proper ratio for crawling.

GATE 01 LINKS BUILD: BAG 6

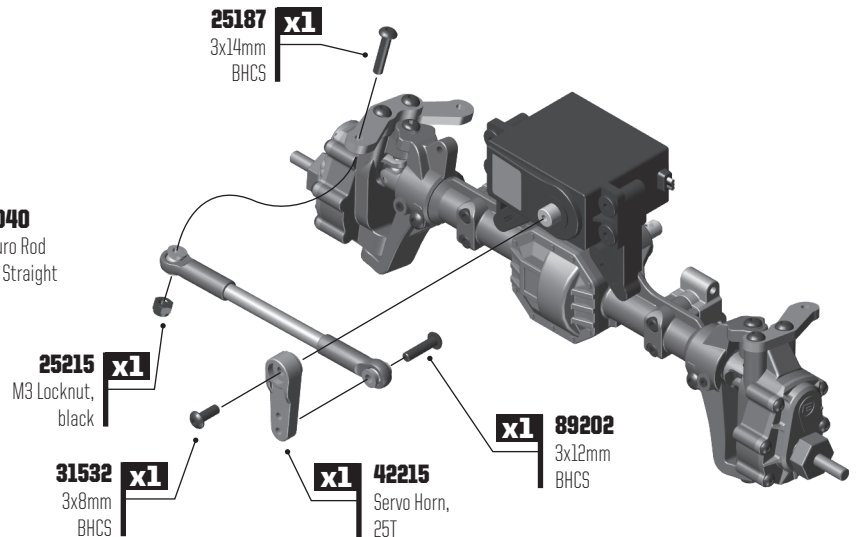
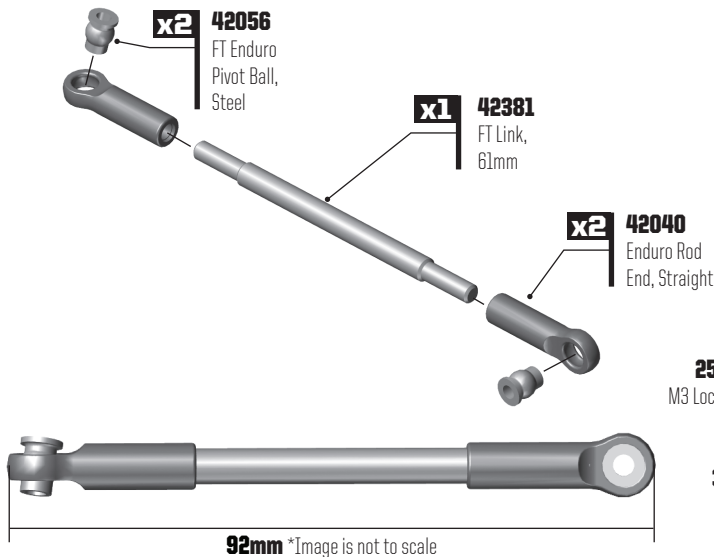

GATE 02 LINKS BUILD: BAG 6

x2 42056 FT Enduro Pivot Ball, Steel

x1 42384 FT Link, 71mm

x2 42040 Enduro Rod End, Curved

x1 25187 M3x14mm BHCS

x2 42056 FT Enduro Pivot Ball, Steel

x3 25215 M3 Locknut, black

x2 42260 Shim, 2mm

x1 71037 3x45mm BHCS

NOTE: Check the rod end angles before installation

101mm *Image is not to scale

BUILD LEFT AND RIGHT SIDES

GATE 03 LINKS BUILD: BAG 6

x2 42056 FT Enduro Pivot Ball, Steel

x1 42180 FT Steering Link

x2 42040 Enduro Rod End, Curved

x2 25187 M3x14mm BHCS

x2 25215 M3 Locknut, black

NOTE: Check the rod end angles before installation

154.50mm *Image is not to scale

BUILD LEFT AND RIGHT SIDES

GATE 04 LINKS BUILD: BAG 6

x2 42056 FT Enduro Pivot Ball, Steel

x1 42040 Enduro Rod End, Straight

x1 42385 FT Link, 121mm

x1 42040 Enduro Rod End, Curved

x3 25215 M3 Locknut, Black

x2 25187 M3x14mm BHCS

x1 41078 M3x28mm BHCS

NOTE: Check the rod end angles before installation

144mm *Image is not to scale

BUILD LEFT AND RIGHT SIDES

GATE 05 LINKS BUILD: BAG 6

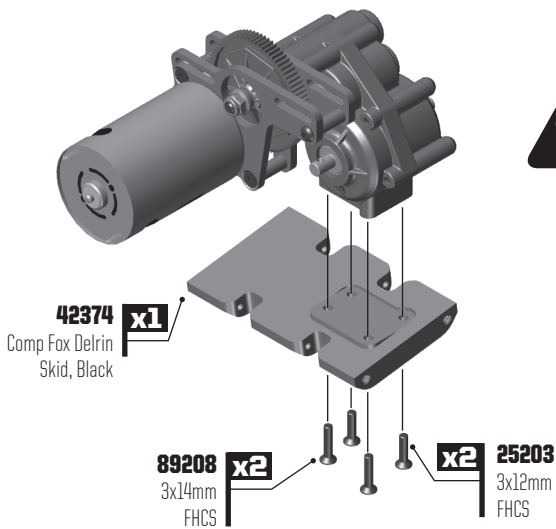

NOTE: Re-tighten the chassis brace screws once the skid plate/transmission build is installed.

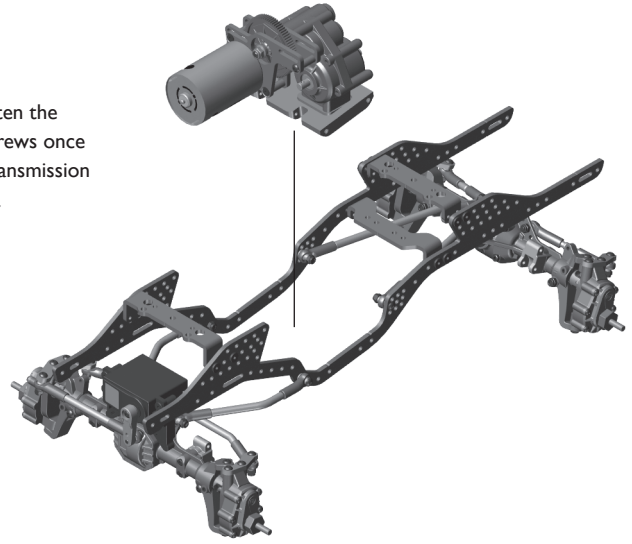

GATE 06 LINKS BUILD: BAG 6

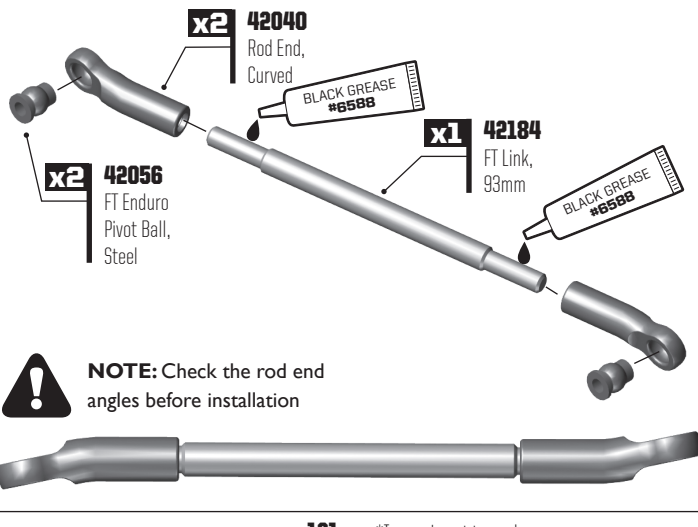

NOTE: Check the rod end angles before installation



BUILD LEFT AND RIGHT SIDES

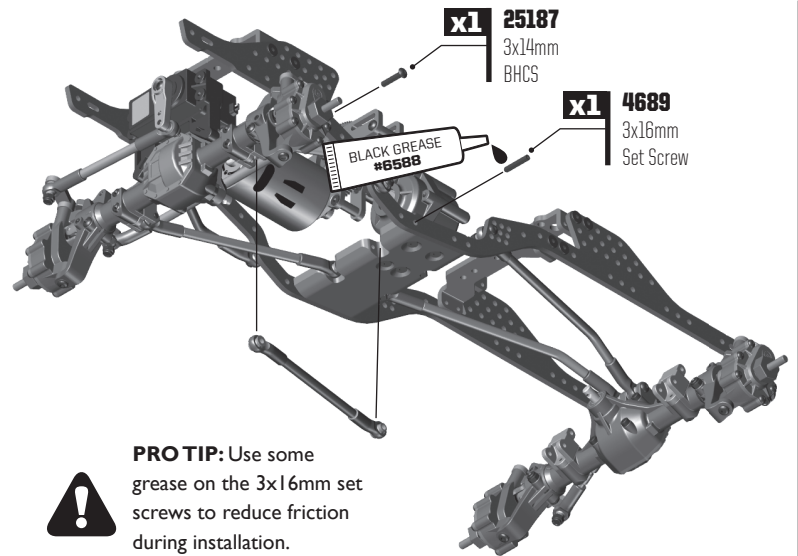

PRO TIP: Use some grease on the 3x16mm set screws to reduce friction during installation.

GATE 07 LINKS BUILD: BAG 6

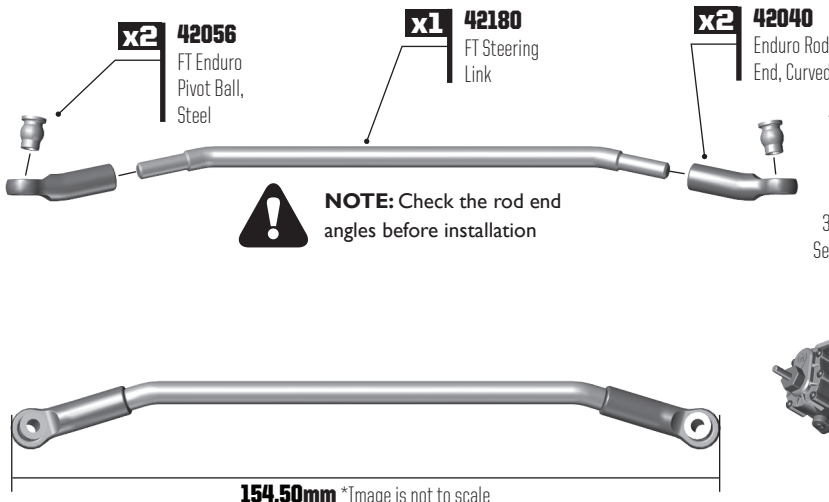

NOTE: Check the rod end angles before installation



BUILD LEFT AND RIGHT SIDES

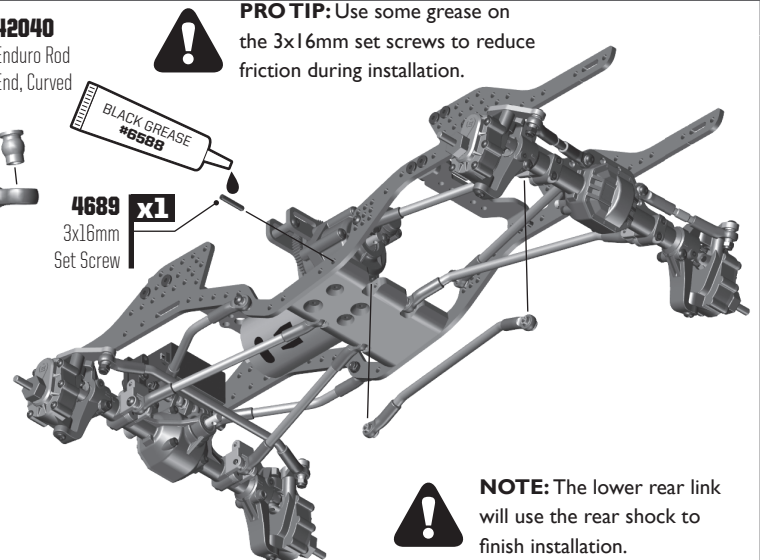

PRO TIP: Use some grease on the 3x16mm set screws to reduce friction during installation.



NOTE: The lower rear link will use the rear shock to finish installation.

GATE 08 LINKS BUILD: BAG 6

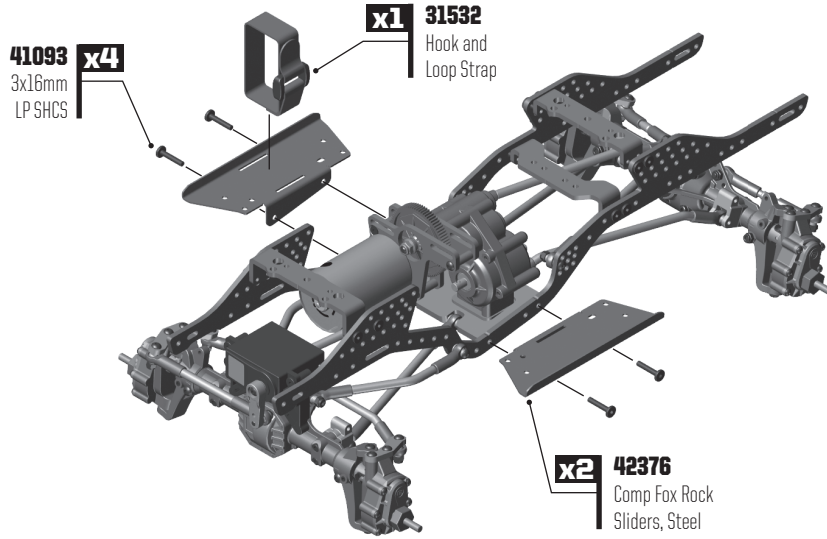

GATE 01 DRIVESHAFTS BUILD: BAG 7

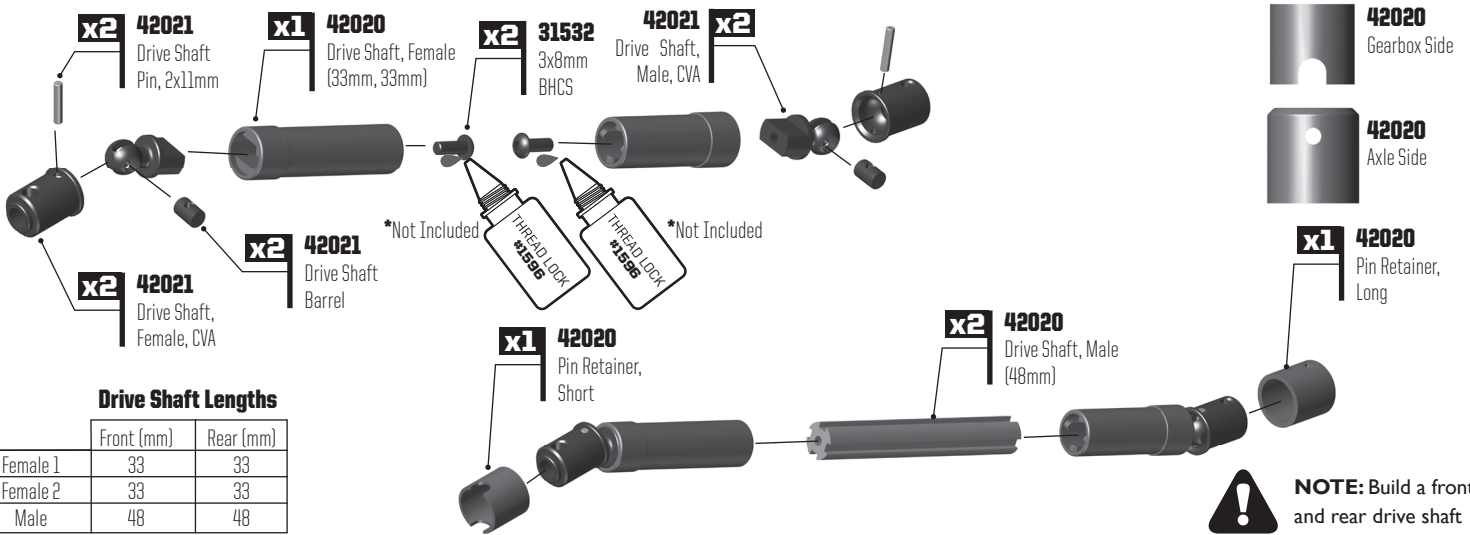

Drive Shaft Lengths

| | Front (mm) | Rear (mm) |
|----------|------------|-----------|
| Female 1 | 33 | 33 |
| Female 2 | 33 | 33 |
| Male | 48 | 48 |

GATE 02 DRIVESHAFTS BUILD: BAG 7

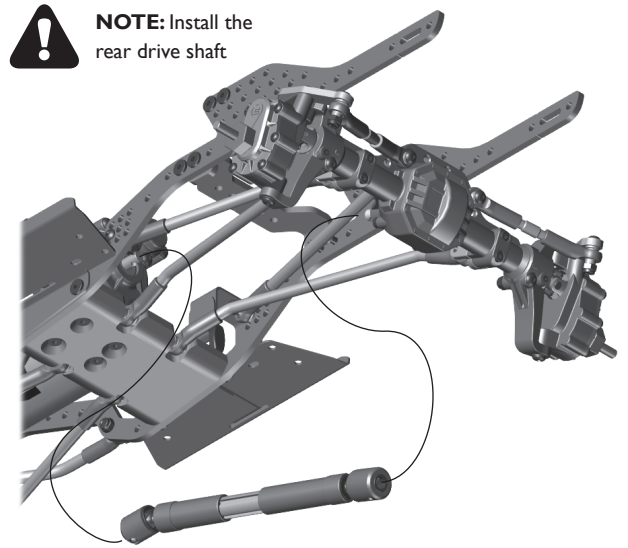
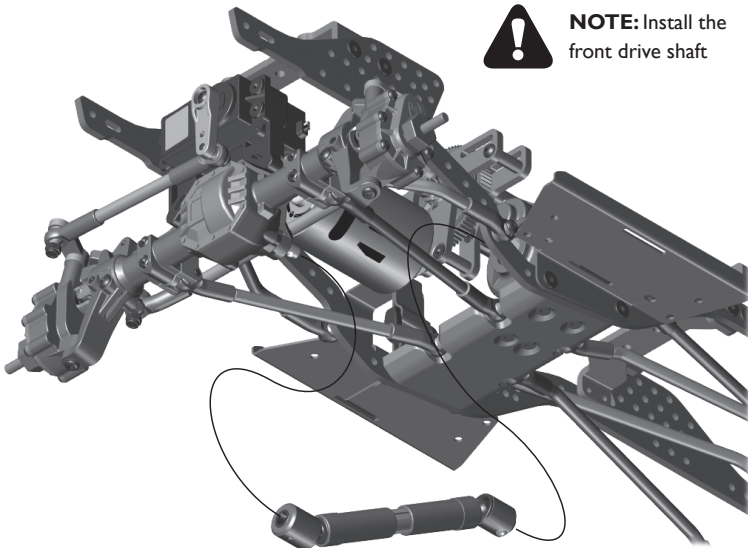

GATE 03 DRIVESHAFTS BUILD: BAG 7



NOTE: Make sure the screw pins are aligned with each female CVA during assembly



NOTE: Make sure the phasing of the drive shafts is correct when installing them to the axles and gearbox.

Correct Phasing



Incorrect Phasing

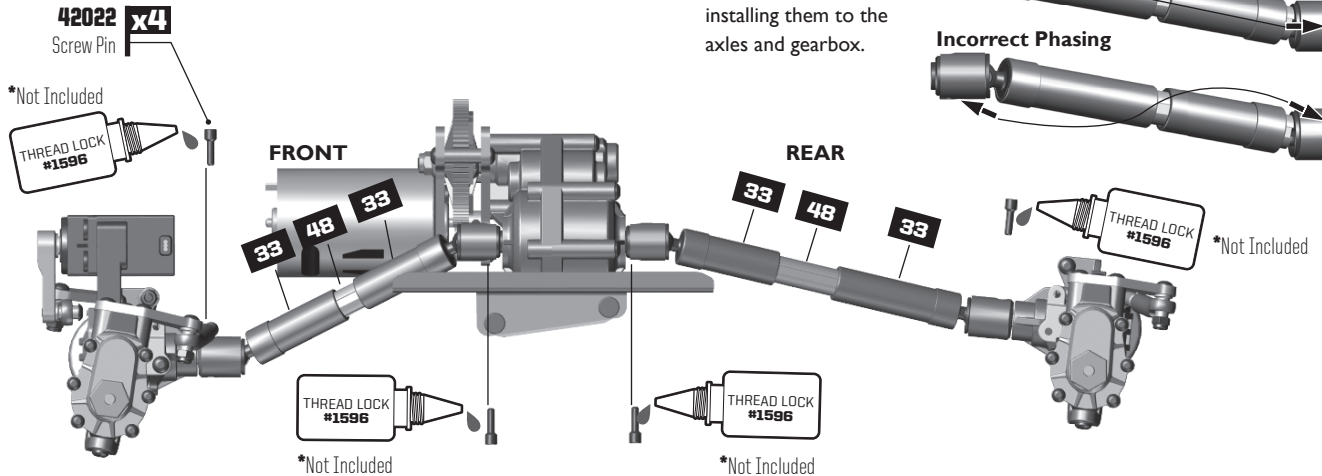
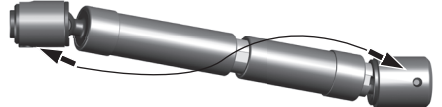

GATE 01 SHOCK BUILD: BAG 8

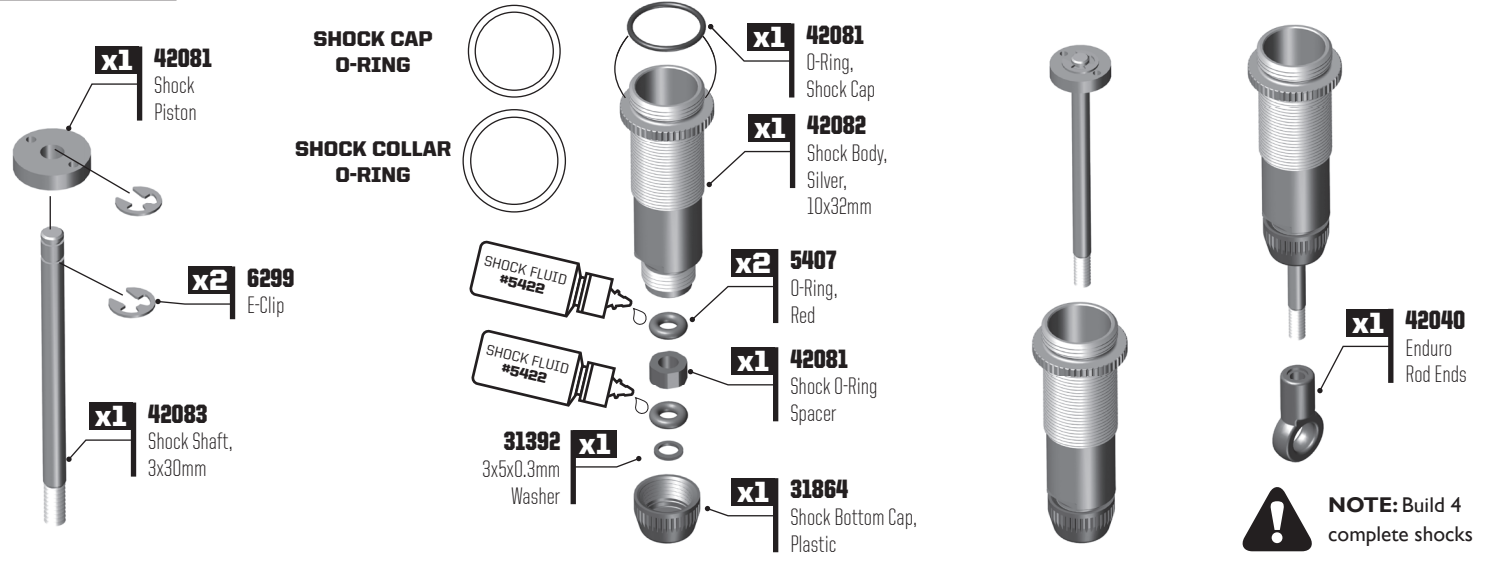

NOTE: Build 4 complete shocks

GATE 02 SHOCK BUILD: BAG 8

Shock Bleeding Steps:

1. Pull shock shaft down.
2. Fill shock body 3/4 full with shock fluid.
3. Slowly move the shock shaft up and down to remove air from under piston.
4. Wait for bubbles to come to surface.
5. Fill shock body to top with silicone fluid.
6. Place a drop of oil in the cap and on cap threads.
7. Install cap and tighten completely.
8. Slowly compress shaft all the way to the top. If there is pressure at the top of the stroke, there is too much oil or air. You must bleed it out.
9. Slowly pull shaft out.
10. Unscrew the cap 3/4 turn and tilt the shock at a slight angle.
11. Slowly compress the shaft to push out excess oil and air. You should see bubbles coming out from under the cap.
12. With the shaft compressed, tighten the cap and re-check for pressure at the top of the stroke. If there is still pressure, repeat steps 9 thru 11.



NOTE: Build 4 complete shocks

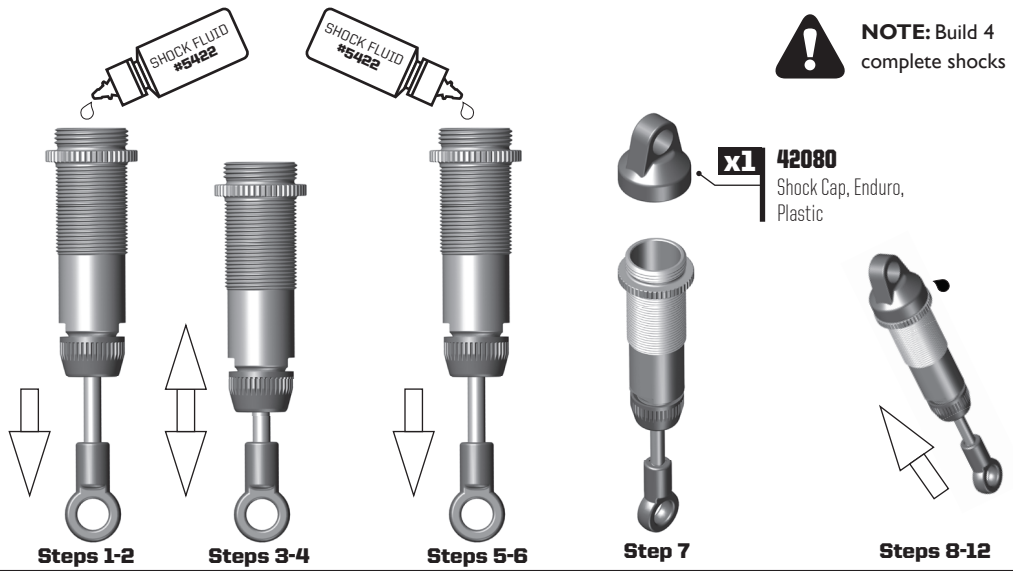

x1 42080 Shock Cap, Enduro, Plastic

GATE 03 SHOCK BUILD: BAG 8

SHOCK CAP
O-RING

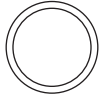

SHOCK COLLAR
O-RING

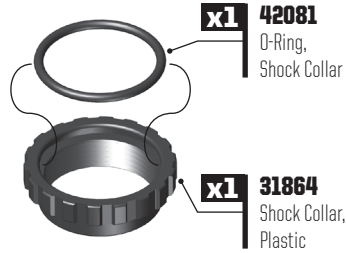
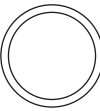

Pro Tip: Use your finger to rub shock fluid on the o-ring for smoother adjustment.

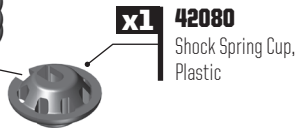

3mm

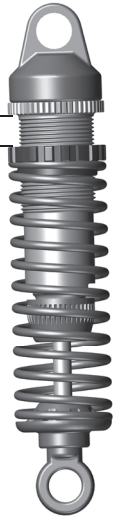

NOTE: Build 4 complete shocks

GATE 04 SHOCK BUILD: BAG 8

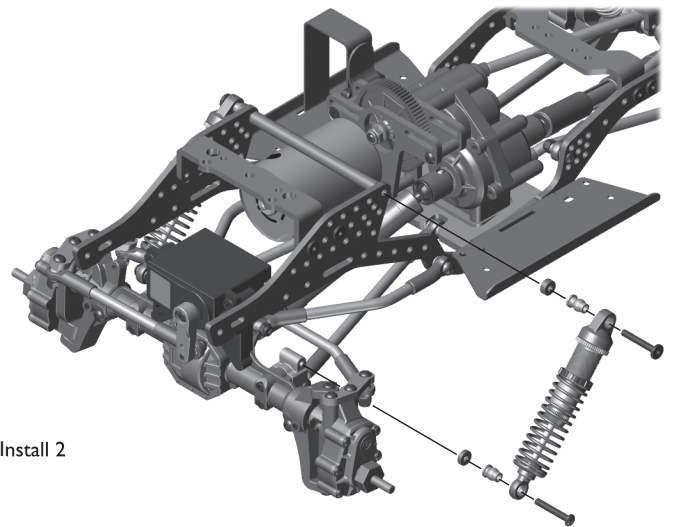
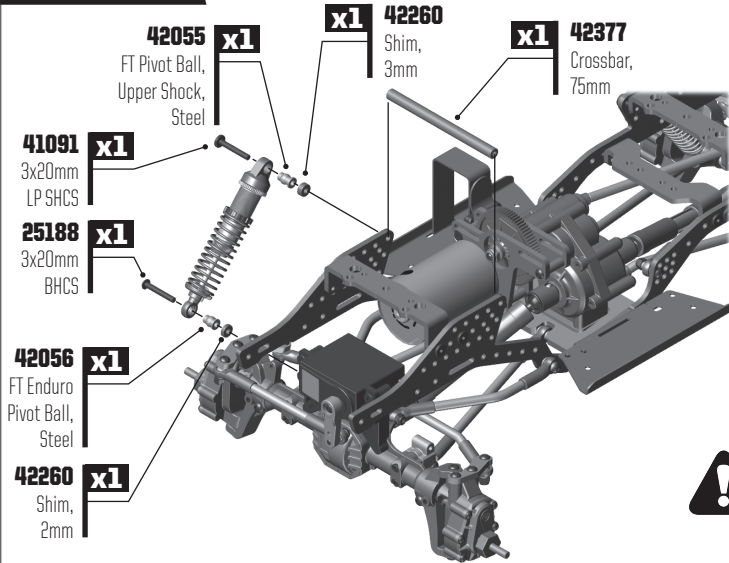

NOTE: Install 2 shocks

GATE 05 SHOCK BUILD: BAG 8

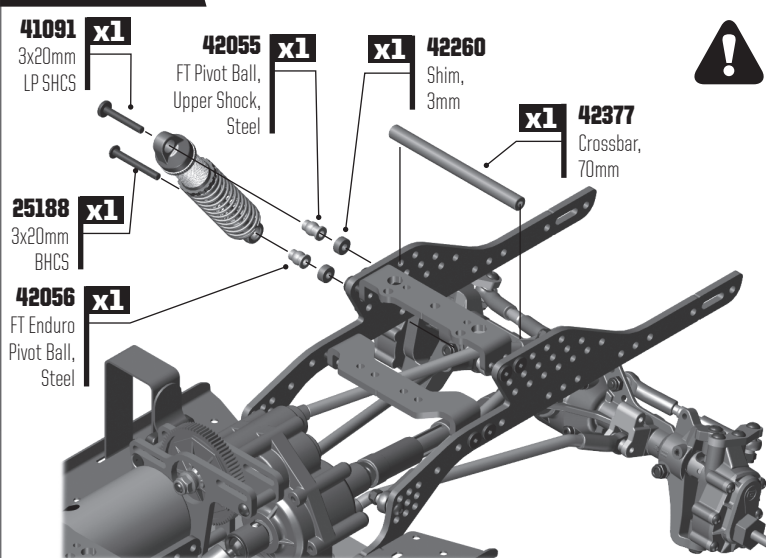

NOTE: Install 2 shocks

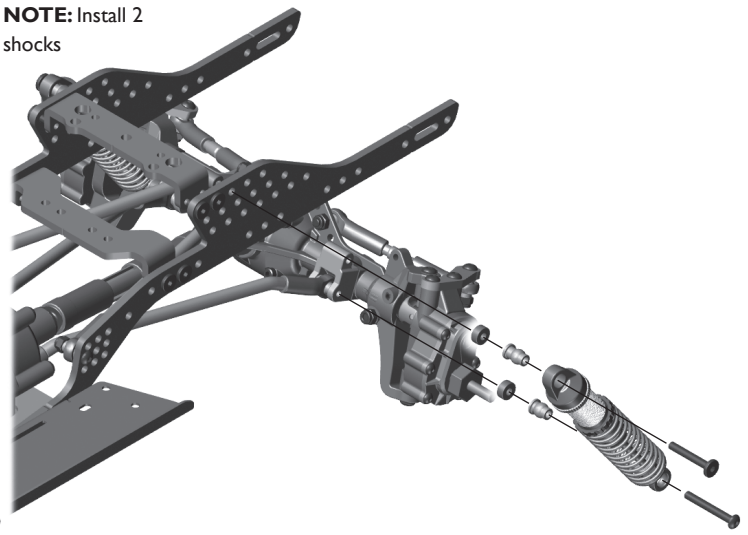

GATE 01 BODY MOUNTS BUILD: BAG 9

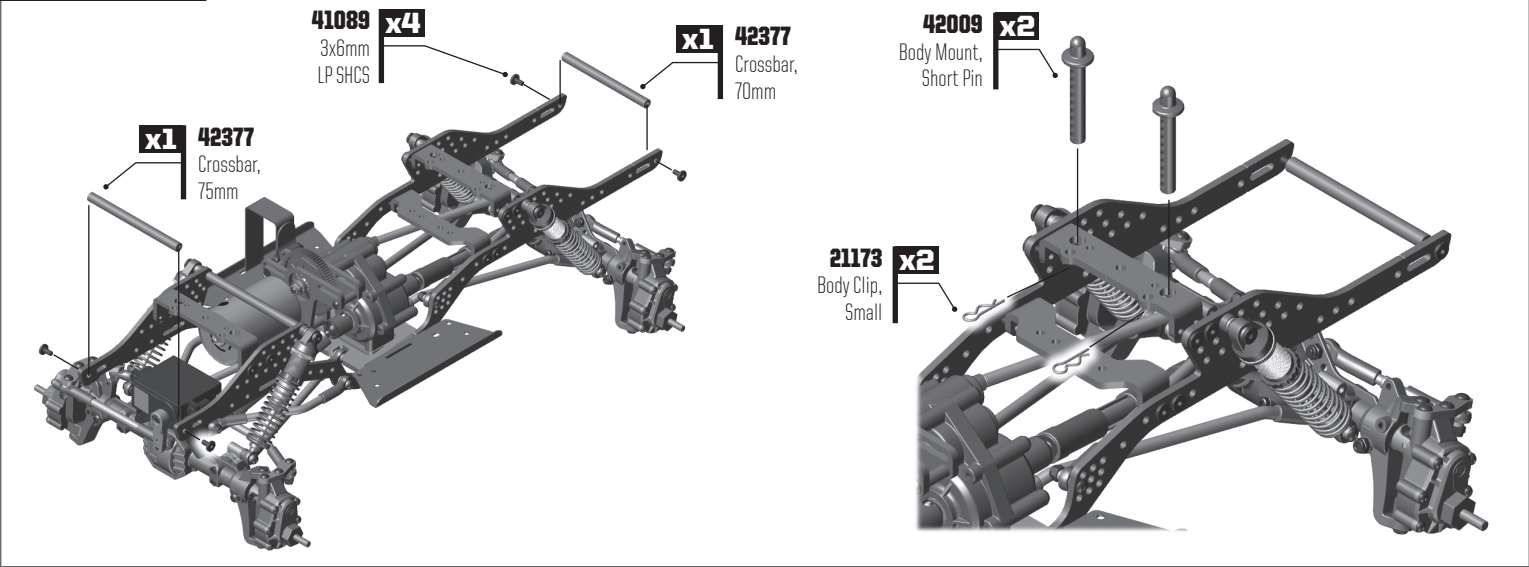

GATE 02 BODY MOUNTS BUILD: BAG 9

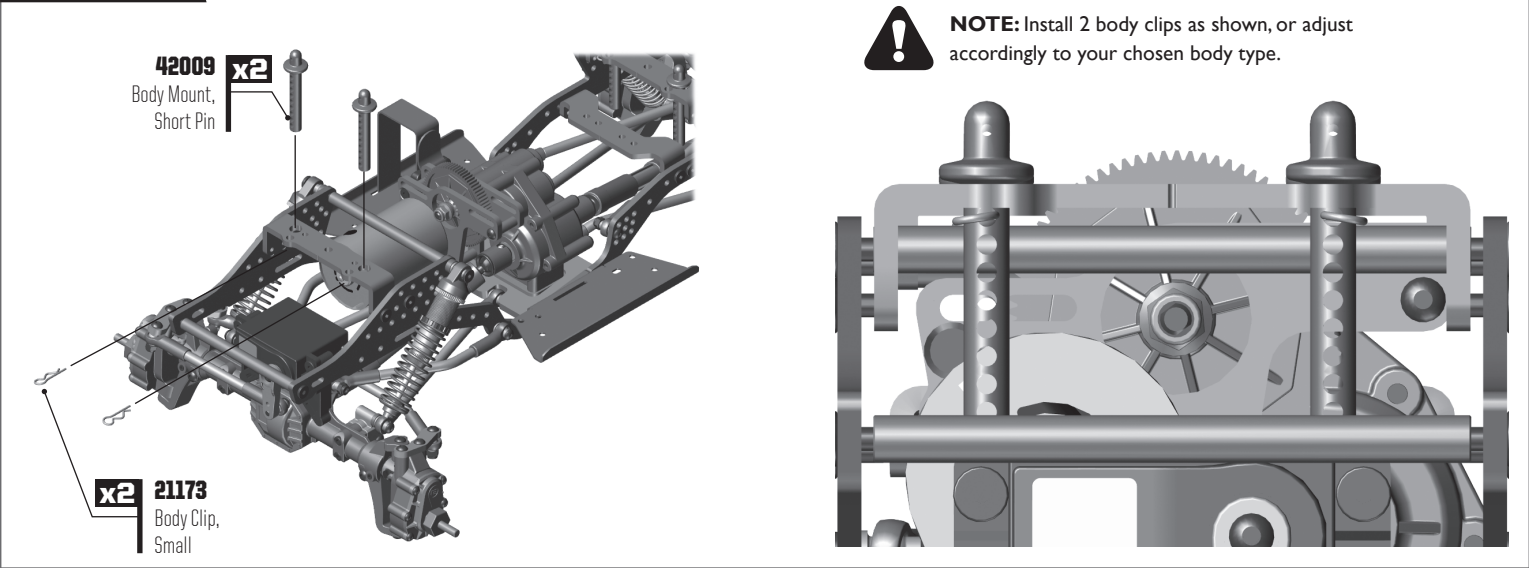

GATE 03 BODY MOUNTS BUILD: BAG 9

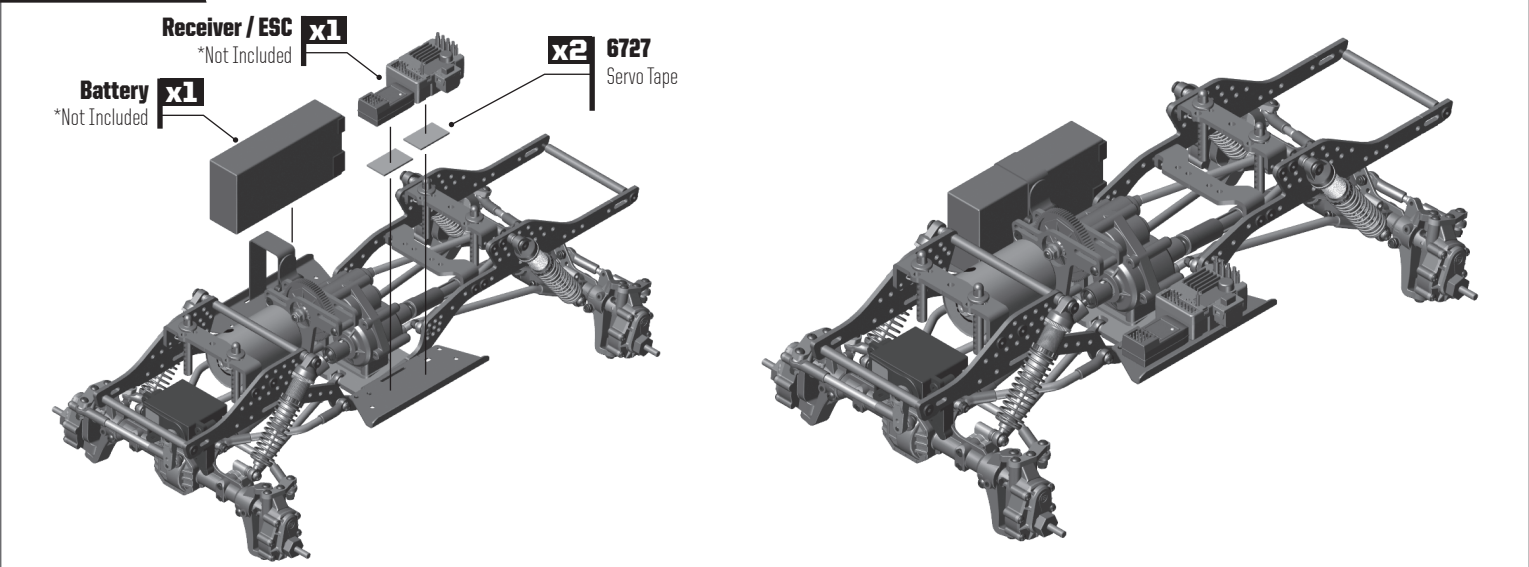

GATE 01**STEALTH X: BUILD CONFIGURATION: MOTOR MOUNT FACING REAR (STOCK)****OVERDRIVE:**

Overdrive is a scenario where the front and rear wheels do not rotate at the same speed. The Stealth X gearbox is designed to allow the front wheels to spin faster than the rear wheels. Overdrive is advantageous when climbing up rock faces because the front tires will want to pull the vehicle up the rock. On descents, the rear tires rotating slower than the front tires will help keep the chassis more stable and keep the rear tires planted on the ground.

Stealth X:

The Stealth X gearbox allows the driver to change the front-to-rear drive ratios with 3 separate ratio adjustments to the rear drive shaft. The driver has the option to flip the gearbox direction (motor mount facing the rear). The optional top shaft (#42030) is required.

Please Note:

The 20T top shaft, 28T idler gear, and 52T drive gear will always be meshed together in all 6 gearbox configurations.

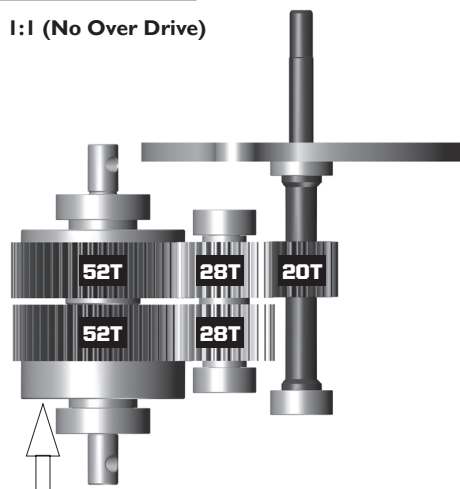
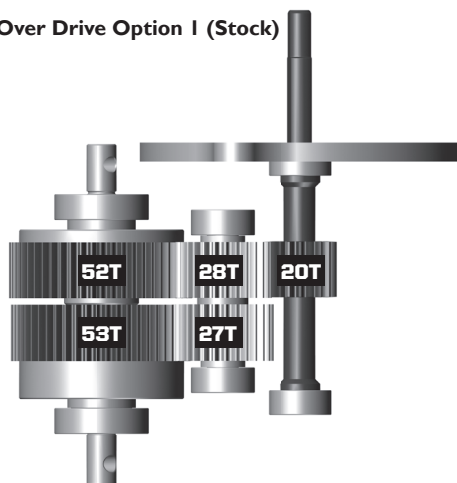
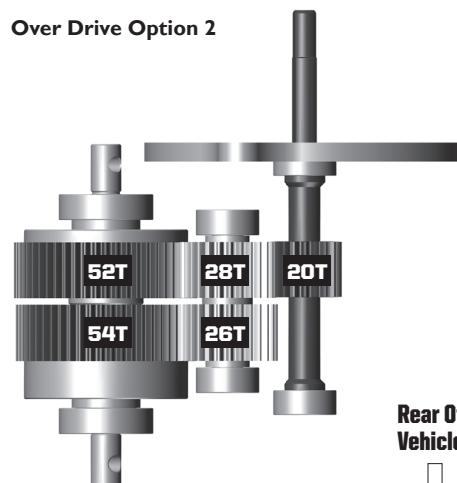
GATE 02**STEALTH X: BUILD CONFIGURATION: MOTOR MOUNT FACING FRONT (STOCK)****I:1 (No Over Drive)****Over Drive Option 1 (Stock)****Over Drive Option 2****Front Of Vehicle****Rear Of Vehicle****GATE 03****NOTES:**

TRAIL TIPS AND CHECKLIST

PREPARING TO HIT THE TRAIL:

When preparing to hit the trail, it's a good idea to have a checklist to make sure you have everything and don't end up having to head back early. We've compiled a checklist of the things we think you'll need on the trail. We've also left some space for you to add your specific items to the list. Keep in mind these are suggestions and every person will require different items. Weather and altitude will also dictate how much food and water a person will require. Do a little research first before heading out for a full day on the trail.

- Truck with Charged Battery
- 1-2 spare Charged Batteries for your rig
- Radio with Charged Batteries
- Spare radio batteries
- Check all nuts and screws and tighten them. Including Wheel nuts!
- Spare parts (Nuts, Screws, Body Clips, and anything that may wear or break)
- Backpack
- Water (2 liters per person minimum)
- Snacks (protein bars, trailmix, etc.)
- Sturdy shoes (Hiking boots preferably or something with grip and ankle support)
- Element Hat or Beanie
- Element Hoodie or Jacket
- Sunscreen
- Bug Spray
- Lip Balm
- Nut Drivers (Factory Team Nut Drivers #1507, 1508)
- Allen wrenches (Factory Team Hex Driver set #1655)
- Cell phone and charger
- Headlight or flashlight with spare batteries
- Compact action camera
- Camera
- Tripod
- _____
- _____
- _____
- _____
- _____
- _____

TREAD LIGHTLY:

Remember, when driving your rig out on the trails, it's important to tread lightly. We all know that the best place to enjoy our hobby is out in nature, and that means we need to preserve it for future hobbyist so we all have a place to enjoy. Here are a few tips to remember when out on the trail.

• Pack In/Pack Out:

Don't leave anything behind. Whether it's trash, parts, or food. If you brought it, take it with you.

• National and Public Parks:

If visiting a national park, leave the RC cars at home. It is illegal to drive any radio control vehicle within national park boundaries. Public parks are slightly different, some may allow radio control cars and others may not. Check with your local officials before driving in a public park.

• Be Considerate:

Where ever you drive your radio control car, always be considerate of others. Hikers, bicyclists, and animals should always be given the right of way.

• Keep It Quiet:

If you're sharing an area with other people, try to keep the noise to a minimum. If you come across animals or anglers, please be considerate and give them space.

• Give A Hoot, Don't Pollute:

When enjoying the outdoors take your trash with you. Not only is it bad for the environment, it's unsightly. If you see trash, pick it up, even if it isn't yours. If we all do our part we can work together to keep our planet beautiful for future generations.

• Only You Can Prevent Wild Fires:

Some of us like to mix camping with RC cars. This is great! Just remember to follow all safety precautions and put out any camp fires before calling it a night. Also, be sure to unplug and **store all LiPo batteries in LiPo sacks and a fire resistant storage device.**

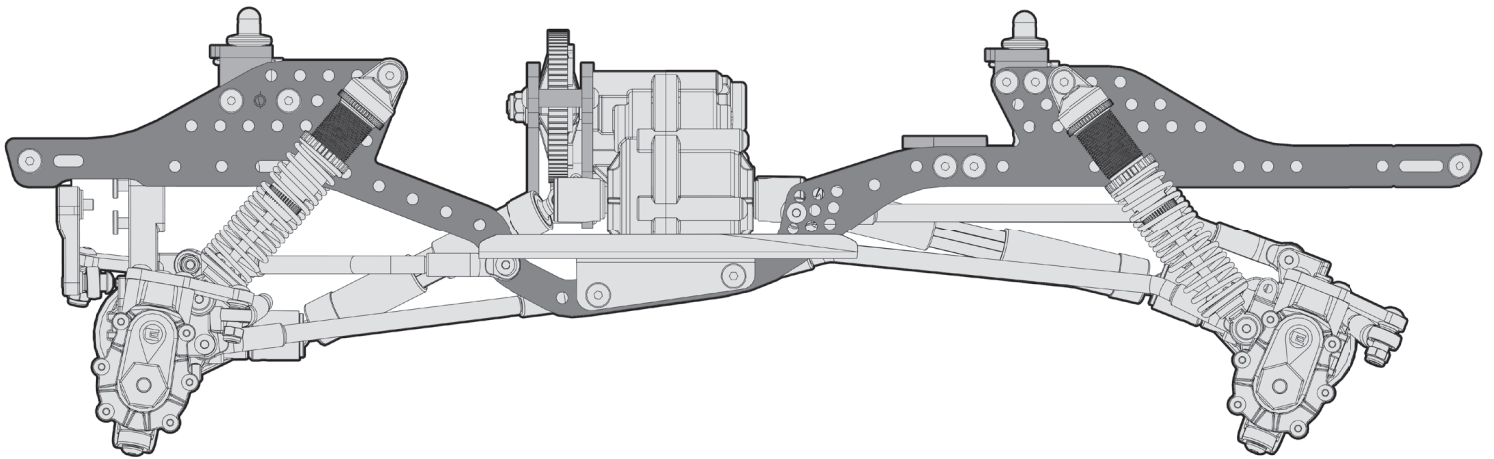

ASSOCIATED ELECTRICS, INC.
21062 BAKE PARKWAY. LAKE FOREST, CA 92630 USA

CALL: (949) 544-7500 - FAX: (949) 544-7501
CHECK OUT THE FOLLOWING WEB SITES FOR ALL OF OUR KITS,
CURRENT PRODUCTS, NEW RELEASES, SETUP HELP, TIPS, AND RACING INFO!
WWW.ASSOCIATEDELECTRICS.COM



ElementRC



@Element_RC